

AFTER INSTALLATION THE END USER SHOULD
KEEP THIS GUIDE FOR FUTURE REFERENCE
DO NOT THROW AWAY

envirovent®

ATMOS® WALL
INSTALLATION GUIDE

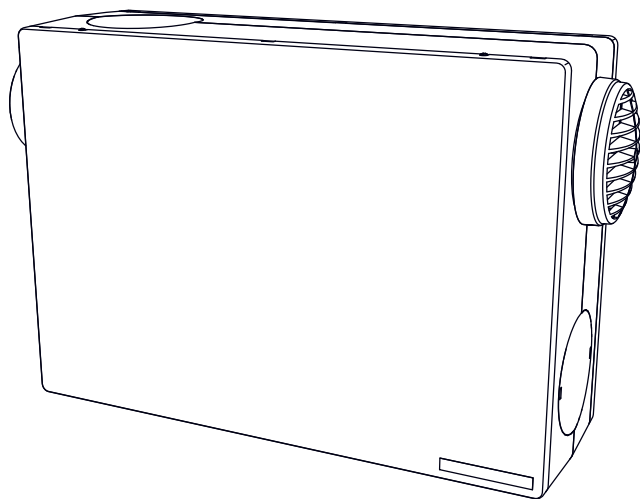

SAFETY

Ensure that you read and understand these instructions before beginning installation. The unit should be installed by a competent person.

LOCATION

Check there is space for the unit in your chosen location including room for access and future servicing of the unit. The unit must not affect the operation of open-flue appliances. Consider the external vent locations in relation to open-flues from appliances e.g. boilers. You must ensure the external supply grilles are positioned away from open flues to avoid drawing harmful gases into the property. Consult your local regulations or a qualified gas engineer. EnviroVent recommends at least 2m clearance. The unit should not be installed in wet rooms.

After installation, the air outlet must face a minimum 1m unobstructed path away from any smoke detectors, walls or other obstructions. For installations where the unit is required to connect to a smoke alarm see page 10 for wiring instructions.

USERS

This unit can be used by children above 8 years and by people with reduced physical sensory or mental capabilities or lack of experience and knowledge if they have been instructed on the safe use of the unit and they understand the hazards involved. Children must not play with the unit. Cleaning and user maintenance must not be performed by children without supervision.

ELECTRICAL CONNECTION

All wiring must comply with Building Regulations and the current IET Wiring Regulations (BS7671 in the UK) or equivalent standards for other countries. All wiring should be completed by a competent person and the final installation should be examined and tested by a qualified electrician.

The unit requires a continuous electrical power supply. Connection to the fixed wiring must be made outside the unit in a suitable location. The unit must be able to be disconnected from the mains supply after installation. The unit must be earthed and a suitable isolator with minimum contact separation of 3.0mm must be used to provide isolation for the unit (see the wiring diagram on page 2). When wiring the unit, the included unswitched fuse spur should be incorporated in the fixed wiring.

The power supply cable running into the unit must remain the supplied flexible cable (not a solid core lighting cable). If the power supply cable becomes damaged, it must be replaced by EnviroVent, an authorised service agent for your region/country, or a similarly qualified person in order to avoid a hazard. Do not remove or tamper with any electronic components inside the product.

This product is not suitable for use with a Type AC RCD 

DIAGRAMS

WIRING DIAGRAM

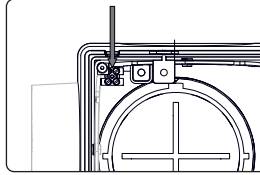

Cable connection location for 0-10V or heater enable input depending on model variant.

0-10V INPUT CABLE
APP/Wireless Remote Control units only. On the ATF model this can be used to connect the optional heater enable/disable switch

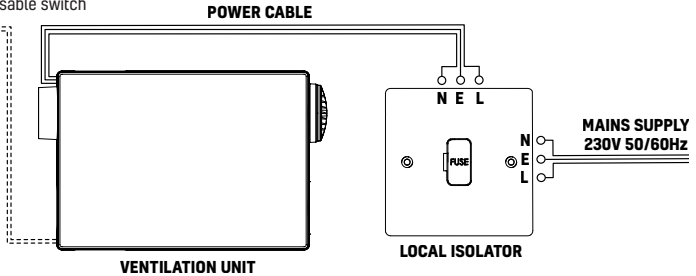
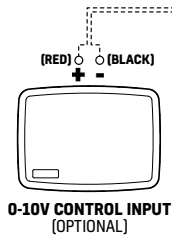

The local isolator must be connected to the mains as part of the fixed wiring. Connect the neutral, live and earth cores of the power cable to the matching terminals on the local isolator.

App / Wireless Remote Control units can be connected to a 0-10V input device if required via the terminal block at the end of the two core cable inside the unit labelled 0-10V input [see installation steps for details]. On the ATF model this can be used to connect the optional heater enable/disable switch.

Do not connect the 0-10V or heater enable/disable input cable to the mains power supply.

DIAGRAMS

DIMENSIONS (+ Minimum area required for access/maintenance)

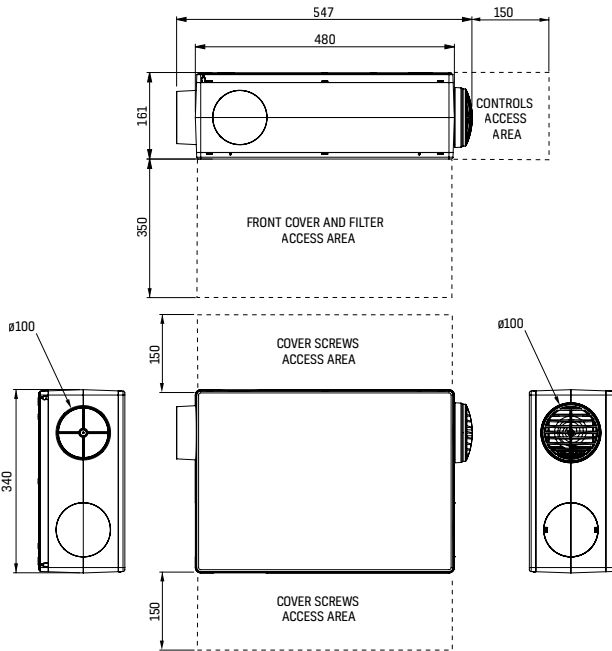

INTERNAL ACCESS (for installation, filter replacement and maintenance)

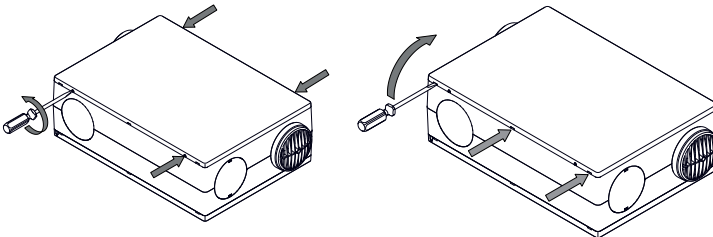

1. Isolate the unit from the mains power supply.
2. Undo all four screws around the front cover. Then unclip the front cover from the unit using a flat head screwdriver in the three slots along one of the cover edges.
3. Gently pull the cover away from the unit.

CONTROLS

CONTROL ACCESS

CONTROL PANEL ACCESS

To access the control panel, unclip the cap using a small flat head screwdriver.

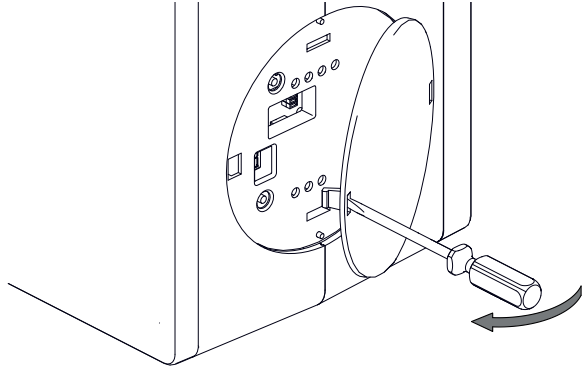

CONTROL PANEL

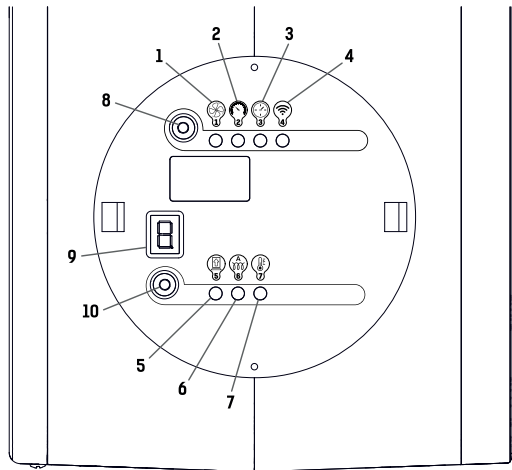

- 1 - Set airflow
- 2 - Variable airflow
- 3 - Hours run
- 4 - Wi-Fi
- 5 - Filter

- 6 - Additional Modes [see settings page]
- 7 - Comfort heater / Summer mode
- 8 - Top button
- 9 - Numeric display
- 10 - Bottom button

ABOUT THE ATMOS WALL

The ATMOS Wall is a Positive Input Ventilation (PIV) unit which helps to create a fresh and healthy living environment by supplying filtered air into a property at a continuous rate. The air is normally supplied via a vent in the central hallway area of the property.

The ATMOS Wall has been developed to improve indoor air quality and resolve condensation and mould problems. It is designed to operate continuously with no requirement for maintenance other than replacement of the filter, general cleaning and a 5 year service.

In conditions between 19°C to 25°C the ATMOS Wall will increase the airflow rate by 10%. In colder conditions below 10°C (default), the automatic heater will temper the incoming air.

BOX CONTENTS

Item Description	Quantity
ATMOS WALL UNIT	1
INSTRUCTION GUIDE	1
APP GUIDE (app enabled units only)	1
UNSWITCHED FUSE SPUR	1
REMOTE CONTROL (wireless remote control units only)	1
MOUNTING SCREWS (8g x 2.0")	4
WALL PLUGS	4
INSTALLATION TEMPLATE	1

PRE-INSTALLATION CHECKLIST

Hold the unit up to the chosen install location:

- Does the unit fit in the space where it will be installed?
- Is there enough space for duct access after installation?
- Is there enough space for control panel access during use?
- Is there room to access and replace the filter after installation?
- Is the mounting surface strong enough to support the unit?
- Is the mounting surface level?

INSTALLATION

1. Undo all screws around the edges of the front cover. Unclip the front cover from the unit using a flat head screwdriver in the three slots along one of the cover edges. Now gently pull the cover away from the unit.
2. Decide which one of the six available air entry points will be used.
3. To switch air entry points, remove the spigot by rotating it 45° anti-clockwise and pulling it in to the unit. Use the same method to remove one air inlet blanking cap. Swap their positions then reinsert them into the unit, rotate 45° clockwise (you will feel the spigot/cap click into place).
4. Air is supplied to the unit from outside via a 100mm rigid duct. Any exposed duct installed on the air entry side of the unit should be insulated to avoid condensation forming on the duct surface. The unit should be installed as close as possible to the air entry point to avoid very long duct runs.

Optional step - To improve visual appearance, the ductwork can be concealed using box profile.

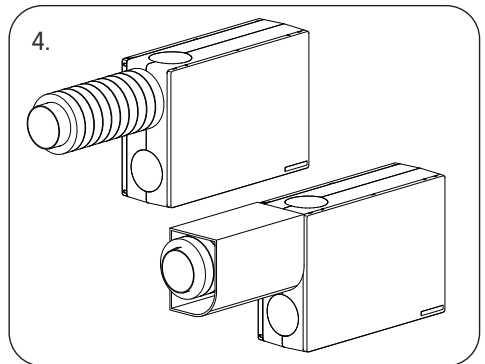
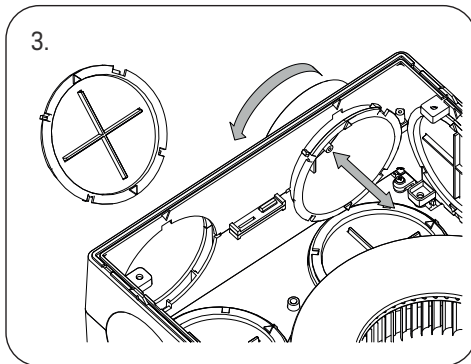
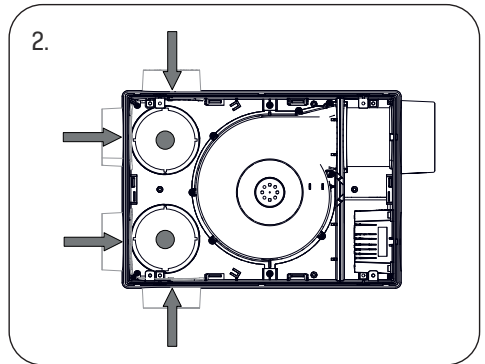
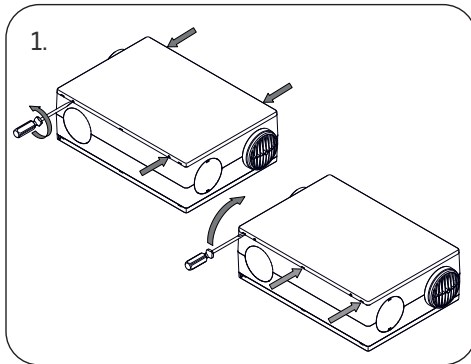

INSTALLATION

5. Decide how the air outlet will be configured:
 - a. Directly through the adjustable supply grille.
 - b. Via 100mm duct to a grille or similar accessory. Undo the centre screw to remove the grille. Fit the duct between the unit and the required air outlet location. The duct should be terminated with an appropriate accessory.

For either option, it is recommended that air is directed upwards towards the ceiling. This minimises noticeable draughts and circulates warm air from ceiling level around the dwelling.

6. The unit is built in a left hand air inlet configuration as standard. If required, the front and rear covers can be unscrewed and swapped around in order to create a right hand air inlet configuration. This reverses the air inlet and air outlet positions.

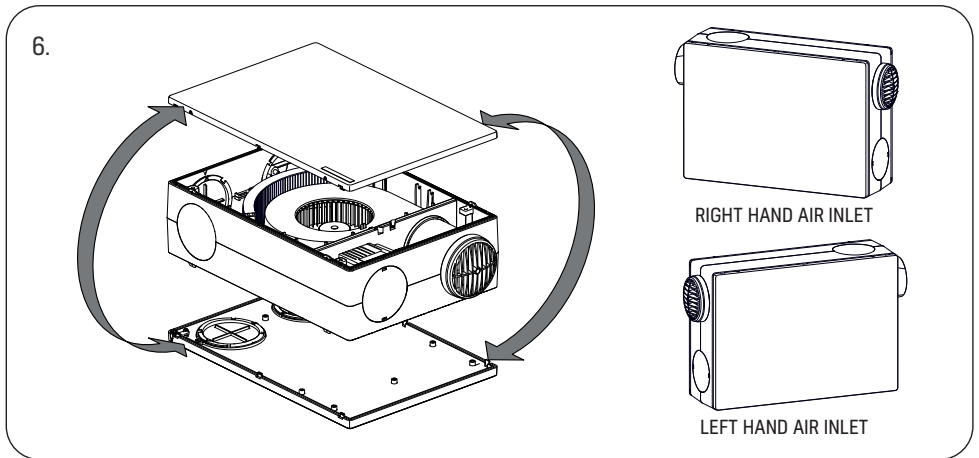
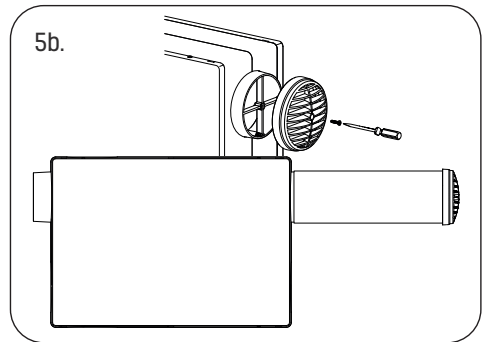
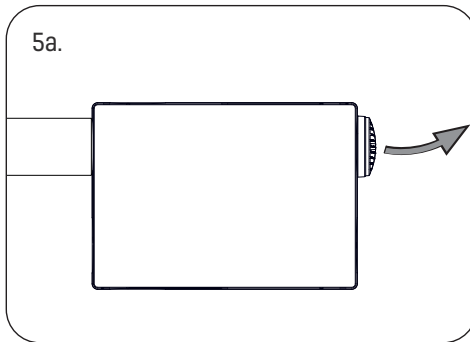

INSTALLATION

7. When you are satisfied with the position, mark the 4x main corner fixing holes onto the mounting surface also refer to the Installation Template. Four alternative fixing points are shown in the diagram. These must be used if any of the main corner fixing points are inaccessible.
8. The power cable is configured to exit the unit at the top left corner [1] as standard. There are three other optional exit points that can be used as required.
9. **OPTIONAL:** To reconfigure the cable exit point separate the rear cover from the unit by removing the 4 screws that secure it. Unscrew the cable clamp and reroute the cable to the required location. Secure the cable with the clamp in the new position.
10. **OPTIONAL:** If required, swap the cable plugs so that all empty holes are filled.

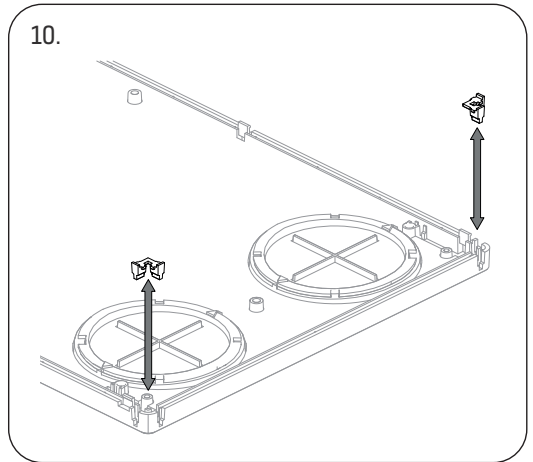
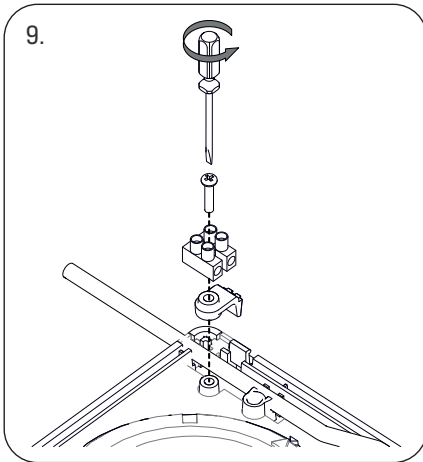
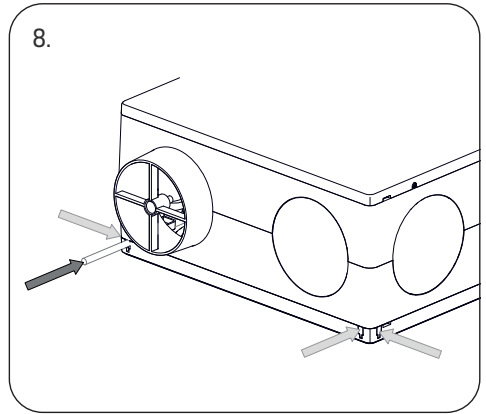
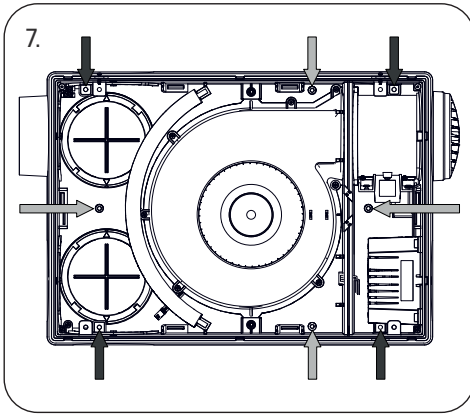

INSTALLATION

11. Attach the unit to the wall ensuring the spigot is inserted securely into the air inlet aperture. Use the 4x 8x2.0" screws and wall plugs supplied.
12. To provide further control over the fan speed, App and Wireless Remote Control units can be connected via a cable to an AirSens intelligent IAQ sensor (optional extra) or other suitable 0-10V control devices. Connect 0-10V devices to the cable connection at the end of the two-core cable labelled "0-10V control input" inside the unit. The cable can be fed into the unit via the notch in the power cable entry slot. (See your chosen device instruction guide for further wiring information). On the ATF model the optional heater enable/disable switch can be wired into this cable connection if one is required
13. With the mains supply isolated, wire the power cable into the local isolator and wire the local isolator to the mains supply (see wiring diagram on page 2). Use the 2x 8g x 1" screws to attach the spur to the wall.
14. Ensure the front cover is fitted then reconnect the mains supply at the local isolator. After a few seconds air will begin to flow from the unit (see pages 13/14 for air flow rate settings).

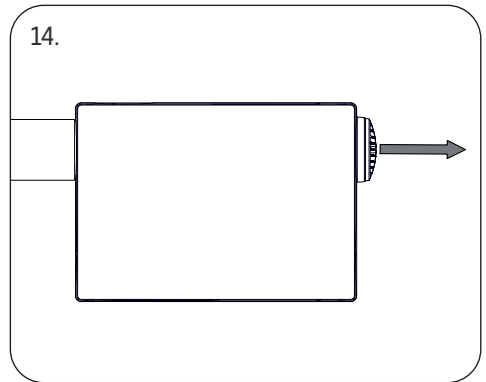
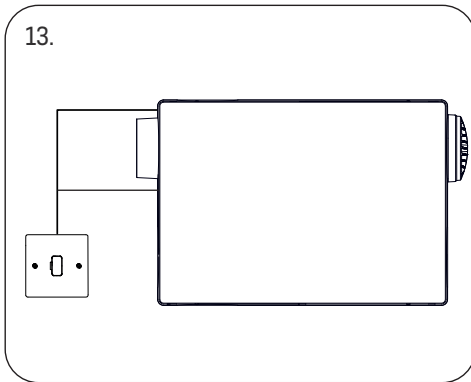
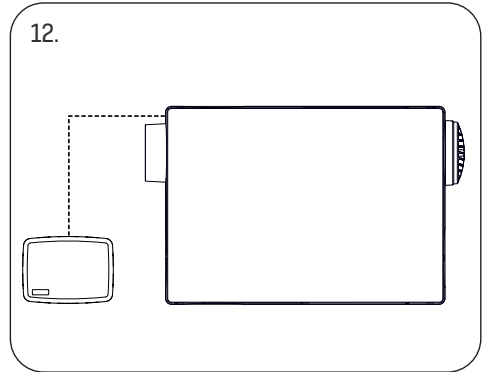
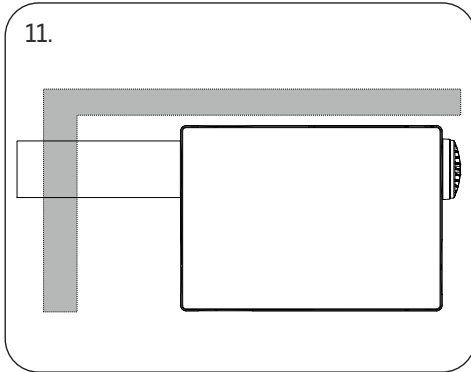

SMOKE ALARM WIRING

For installations where it is required, the Atmos Wall can be wired into a smoke alarm in order to switch the unit off upon the detection of smoke.

If required, a smoke alarm is available as an optional accessory [see page 18].

The smoke alarm used must be mains powered with a hard wired relay module.

Connect the smoke alarm to the unit as shown in the wiring diagram below.

All wiring must comply with Building Regulations and the current IET Wiring Regulations [BS7671 in the UK] or equivalent standards for other countries.

All wiring should be completed by a competent person and the final installation should be examined and tested by a qualified electrician.

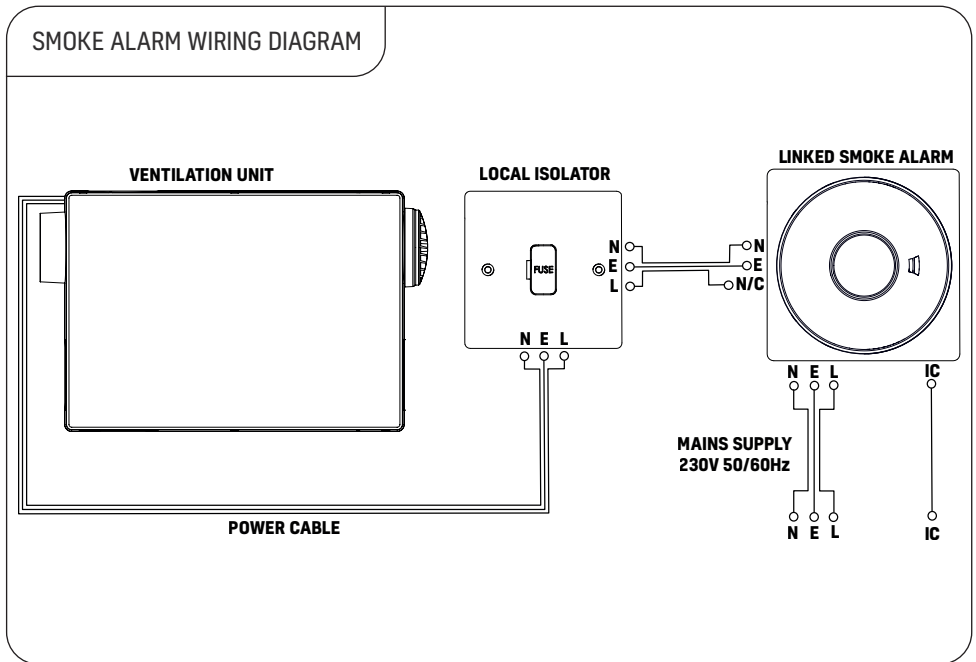

SETTINGS

Top Button:

- Press to activate the numeric display.
- Further presses scroll through the modes on a loop.
- The corresponding LED will illuminate on the keypad.

Bottom Button:

- Press for 2 seconds to modify the settings for the highlighted mode.
- The corresponding LED will flash on the keypad.
- The current setting will be shown on the numeric display.
- Quick press to alter the setting. The available options will scroll on a loop.
- Press for 2 seconds to save changes to the selected mode.
- After 30 seconds of inactivity the numeric display will turn off.

Modes [corresponding display information is shown in bold].

Set airflow rate:

- Selectable airflow rates 1/ 2/ 3/ 4
- When fitted with a carbon filter (FILTERWALL-FINE+C), it is recommended to set the unit to a minimum speed of 2.

Variable airflow rate:

- Variable airflow rate for fine tuning '32' ... '100' (increments of 2% from 32% to %100 of the maximum airflow rate. This will overrides the set airflow rate when engaged).
- The mode will engage after the value has been selected.

Hours run:

- Total time the unit has been running in hours.

Wi-Fi:

- Point to point 'F' (the unit is available for direct connection to a smart device, or for connection to a network)
- Connected to network 'C' (the unit is connected to a network and not available for direct connection to smart device)
- Press the bottom button for 10 seconds to reset the access point.

Filter usage:

- Total usage time remaining [days]
- Filter period setting '12' / '24' / '36' / '48' / '60' [months]
- To reset the filter countdown, hold the bottom button down for 10 seconds. The LED will flash rapidly to confirm the reset.

Additional modes:

- Comfort heater: 'H0' / 'H-' (on / off).
- Comfort heater temperature: 'h5'... 'h15' (Increments of 1°C from 5 to 15) [Increasing the heater temperature will increase energy usage/running costs].
- Boost time: 'b20' / 'b40' / 'b60' / 'b720' [20 mins / 40 mins / 60 mins / 720 mins(12 hours)].
- Summer temperature: 't18'... 't28' (increments of 1°C from 18 to 28). This alters the temperature at which the Summer mode operates.
- Summer mode: 'd0' / 'd-' (on / off). When the Summer mode is on 'd0' it will shut down the unit if the incoming air is higher the Summer temperature.
- Kick up: 'U0' / 'U-' (on / off). With kick up enabled, when the incoming air is above 19°C the unit increases airflow rates per setting by 10%.

Comfort Heater on/off:

- The LED will illuminate when the comfort heater is powered.
- The LED will flash if the unit is in summer mode.

Fault Indication

All of the LEDs will flash if there is a fault. For further help please call: **01423 810 810**

WIRELESS REMOTE CONTROL

To indicate the current status of the unit:

- Press the remote-control button once and the LEDs will light up according to the current status of the unit.

To modify the airflow rate:

- Press the remote-control button once
- Further presses will then cycle the unit through each of the airflow rate settings - 1, 2, 3, 4

To turn the automatic comfort heater function off:

- Press the remote-control button once.
- Press and hold for 5 seconds to disable the comfort heater.
- The AUTO LED will flash red for 5 seconds.

To turn the automatic comfort heater function on:

- Press and hold for 5 seconds to enable/disable or to change the state of the comfort heater
- The AUTO LED will light constant red for 5 seconds.

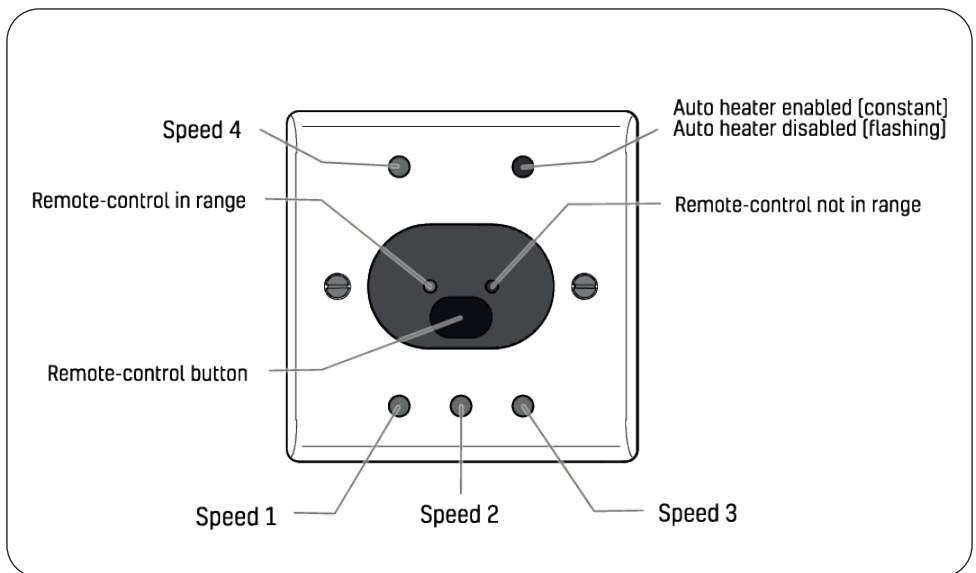

Pairing an additional remote-control

1. Turn the unit off at the isolation point.
2. Restore power; for 20 seconds from restart the unit will be in pairing mode.
3. Press the remote-control button once within the 20 seconds and the control will pair to the unit.
4. Successful pairing is indicated by a green light on the remote control.

Remote control batteries

When the battery needs to be replaced, unscrew the switch front cover. The battery is located on the back of the cover. Battery type: 3 Volt CR2032. The switch will remain paired with the unit after battery replacement. Ensure the new battery is inserted with correct polarity, and the removed battery is safely disposed of.

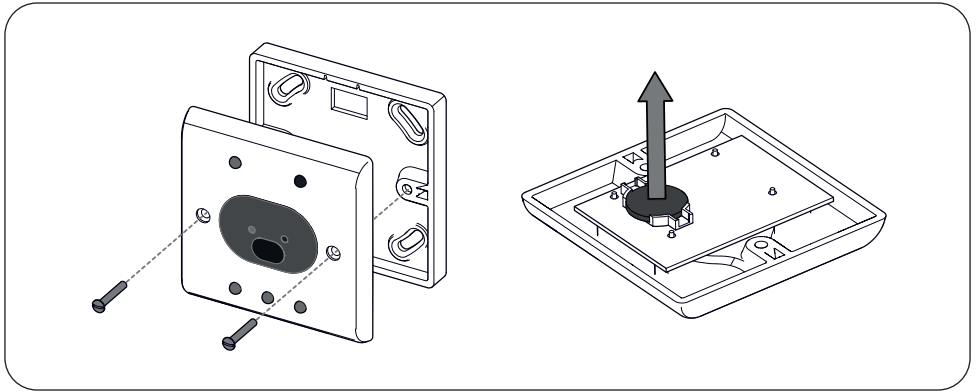

APP - myenvirovent

App units can be controlled via Wi-Fi connection using the myenvirovent app on Apple and Android devices.

- SSID and password information for the unit is labelled on the back page of this installation guide and also on a label attached to the unit.
- A separate instruction guide for the myenvirovent app is included in the box. Once the unit has been installed, refer to the instruction guide for connection and settings.

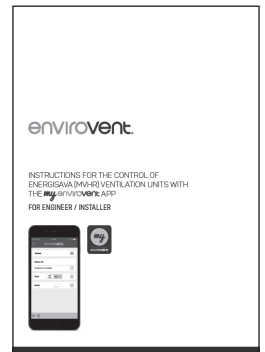

TECHNICAL SPECIFICATION

Extract spigot diameter	100mm
External spigot diameter	100mm
Rated Maximum power consumption	420W
Electrical supply	230V Single Phase 50/60Hz
Ingress protection rating	IPX2
Boxed weight	6kg
Unboxed weight	5kg

RUNNING COSTS

Bathroom & Kitchen

Please scan our QR code to see the annual running costs of this product.

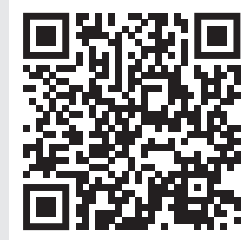

Or visit: envirovent.com/annual-running-costs

Above 19°C the unit increases airflow rates per setting by 10%. Performance data for the unit with duct and grilles.

MAINTENANCE

Filter replacement is required every 12 months. This period may be shorter depending on the environmental conditions. The unit needs to be serviced after 5 years.

TO ACCESS AND REPLACE THE FILTER:

- Isolate the unit from the mains power supply.
- Undo all screws on the front cover and then use a flat head screwdriver to disengage the three clips along the edge of the unit.
- Now gently pull the cover away from the unit.
- Pull the old filter out of the unit and replace it with a new filter (see page 18 for order codes).
- Once replacement is complete, clip the front cover back into position and reinsert the screws.

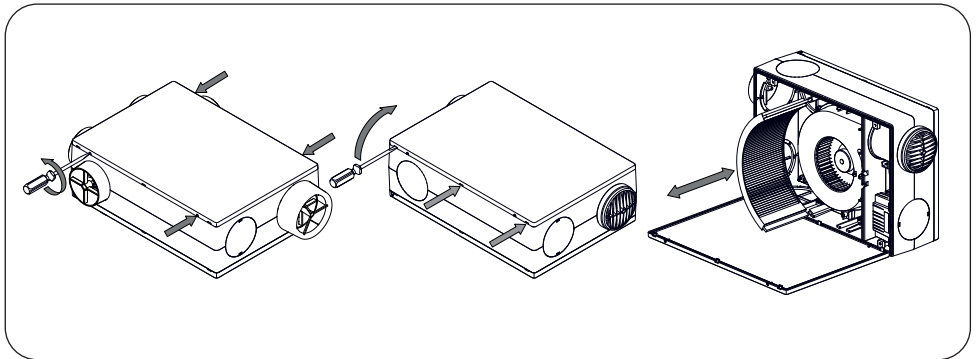

TO RESET THE FILTER USAGE TIMER:

- Scroll through to option five on the settings menu. Hold the bottom button down for 10 seconds. The filter LED (5) will flash rapidly to confirm the reset.

POST-INSTALLATION CHECKLIST

- Installation instructions have been understood.
- Ductwork travelling through unheated areas has been insulated.
- Ductwork travelling to the unit from atmosphere is insulated.
- Minimal amounts of flexible duct have been used in the installation.
- All ducts, valves and vents are connected, mechanically fixed and sealed.
- The unit is securely fixed with adequate space left for maintenance.
- All major building works have been completed prior to commissioning.
- Air flow rates have been commissioned with a calibrated anemometer or other suitable piece of equipment to meet Approved Document F of the Building Regulations for England & Wales.
- Commissioning air flow rate data has been recorded.
- The occupants of the property are familiarised with the operation and maintenance requirements of the system.

Contact EnviroVent on **01423 810 810** if you require further technical help.

SPARES & ANCILLARIES

Item Description	Order Code
Replacement medium particle filter (ePM10 50%)	FILTERWALL-MEDIUM
Replacement fine particle filter (ePM2.5 50%)	FILTERWALL-FINE
Replacement fine particle filter including carbon (ePM2.5 50% including carbon)	FILTERWALL-FINE+C
Fixing Kit	FIXINGKIT-ATMOSWALL
Smoke alarm*	1ACSMOKEALARMKIT
Heater switch**	SWHHEATER
Wireless Remote Control***	SWHRFPiV
AirSens® CO2** •	AIR-CO2
AirSens® VOC** •	AIR-VOC
AirSens® RH** •	AIR-RH
AirSens® TEMP** •	AIR-TEMP
AirSens® CO2 Wireless** • (Requires AIR-REC-RF receiver for use)	AIR-CO2-RF
AirSens® VOC Wireless** • (Requires AIR-REC-RF receiver for use)	AIR-VOC-RF
AirSens® RH Wireless** • (Requires AIR-REC-RF receiver for use)	AIR-RH-RF
AirSens® TEMP Wireless** • (Requires AIR-REC-RF receiver for use)	AIR-TEMP-RF
AirSens® Receiver •	AIR-REC-RF

*Additional four core cable required.

**Additional two core cable required.

***W and A Units only

- AirSens Range suitable for use with W and A units only

WARRANTY

We appreciate you choosing this EnviroVent product, which is designed and manufactured in Harrogate, North Yorkshire. We are confident that you will be delighted with the performance of the system and the resulting improvement in air quality in your home after it has been installed.

This product is covered by a 10-year warranty, if installed by EnviroVent, to the replacement of the filter every 12 months and a service being completed after 5 years. If this product is not installed by EnviroVent, a 5-year warranty is offered." You should not dismantle or remove any parts of the product other than those instructed in this guide. Tampering with the unit will void the warranty. The supply vent should be checked periodically to ensure there is air flowing through the system.

ENVIROVENT SUPPLY AND INSTALLATION: If your product has been supplied by EnviroVent Ltd it is covered by a 10-year parts and labour warranty. If you detect a fault, please contact us on 01423 810 810. You will be given guidance over the phone, or an arrangement may be made for a member of our team to visit [call-out charges may apply].

SUPPLY ONLY: If your product has been supplied by EnviroVent and installed by a third party it is covered by a five-year parts only warranty. If you detect a fault and the product has been installed in accordance with the installation/wiring instructions, relevant guidance documents and by a competent and qualified person [proof may be required], then please return the product to the place of purchase for a replacement.

WARRANTY CONDITIONS & EXCLUSIONS

Please note that a receipt will be required as proof of purchase of both the unit and filters. Products bought from an unapproved source, including but not limited to auction websites, are not covered by the warranty.

- The system must be correctly installed and operated according to the instructions contained in the user guide supplied.
- The warranty will be rendered invalid if the system has been serviced, maintained, repaired, taken apart or tampered with by any person not authorized, which in any way contradicts the instruction guide set out by EnviroVent.

Your unit serial number _____

For warranty conditions and exclusions, visit www.envirovent.com/warranty

AFTER INSTALLATION THE END
USER SHOULD KEEP THIS GUIDE
FOR FUTURE REFERENCE

DO NOT THROW AWAY

envirovent

AFTER INSTALLATION THE END
USER SHOULD KEEP THIS GUIDE
FOR FUTURE REFERENCE

DO NOT THROW AWAY

envirovent

AFTER COMPLETING INSTALLATION, PASS THIS GUIDE
ONTO THE END USER FOR FUTURE REFERENCE
DO NOT THROW AWAY

envirovent®

Leading Manufacturer & Supplier of
Innovative & Sustainable Ventilation Systems

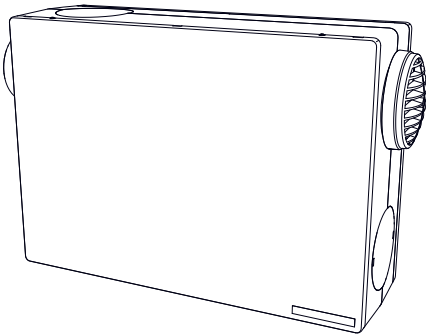

EnviroVent Ltd
Harrogate West Business Park
Unit 1 Bardner Bank
Killinghall
Harrogate
HG3 2SP

T / 01423 810 810
E / info@envirovent.com
W / envirovent.com

Boxed unit weight: 6kg Unboxed unit weight: 5kg

E&OE | MKT ENV415 - V13 - 18.02.25

Due to our policy of continuous innovation and improvement EnviroVent reserves the right to alter products specification and appearance without notice.

We want to hear from you

Your feedback is important to us as we strive to improve our products, services, and overall customer experience. Please email us to help us serve you better: feedback@envirovent.com