

## TECHNICAL DATA SHEET ATMOS® | Whole House Positive Input Ventilation Unit



Lifetime Range\*



### PRODUCT

Whole house positive input ventilation system for properties with a loft space, providing ventilation to improve air quality and resolve condensation related problems.

### APPLICATIONS

The ATMOS® unit is manufactured in the UK and installed in properties with a loft space to meet the Building Regulations Approved Document F.

ATMOS® units supply filtered air from the loft space into a central hallway at a continuous rate via a ceiling mounted diffuser, which comes with two blanking plates to maximise efficiency of airflow and is designed to aid in distribution of heat from ceiling level. The unit provides ventilation in order to improve indoor air quality and resolve condensation related problems taking maximum advantage of the benefits of solar gain from within the loft space.

### INSTALLATION

A full installation guide is enclosed with all products, or sent separately in advance if required. For fitment in 3 floor properties above 4.5m, ATMOS® units should be fitted with a fire rated diffuser and wired to shut off on detection of smoke. The unit is pre-wired with a standard length of cable for connection to the 230V mains supply and a low voltage cable for connection to the auto comfort heater switch. On W and A versions the low voltage cable is reconfigured as a 0-10V input. Duct from the unit to the diffuser is supplied as standard along with a fixing kit.

### INTEGRAL 'INTELLIGENT' COMFORT HEATER

During cold periods, the unit is capable of maintaining the incoming air temperature consistently at 10°C. The integral heater element is manufactured in a solid tubular sheath material.

### CONTROLS

At installation the unit will be set by the installer using the integrated control panel to run at one of the 4 fixed speeds (1,2,3, or 4) depending on the size and occupancy of the property. The unit will run continuously all year round on this setting. An integral hours run meter is fitted on all units for monitoring of operational life and verification of usage.

### Optional controls:

Model **ATL-W** - these units are supplied with a wireless remote control. The user can view the current status of the unit and increase or decrease airflow as required and enable/disable the Auto comfort heater.

Model **ATL-A** - these units are app-enabled. Once the user activates the boost switch in the myenvirovent app, the airflow is boosted for 20 minutes as standard before returning to the commissioned setting. Other functions within the myenvirovent app include: Airflow setting, Filter indicator, Hours run meter, Summer mode control, Auto comfort heater enable/disable.

0-10V variable control input for use with the AirSens® is available on both W and A versions.

### ANNUAL RUNNING COSTS

Please scan our QR code to see the annual running costs of this product or visit:

[envirovent.com/annual-running-costs](http://envirovent.com/annual-running-costs)



### PERFORMANCE & SOUND LEVELS

(as installed figures)

Incoming Air Temp. [°C]	Fan Speed Setting	Specific Fan Power (SFP)	Airflow [l/s]	Power Usage (W) [3]	Outlet Noise dB(A) @3m
<19 [1] [2]	1	0.17	21	4	<15
	2	0.15	29	4	<15
	3	0.16	38	6	<15
	4	0.19	49	9	<15

- Above 19°C the unit increases airflow rates per setting by 10%.
- The unit switches to Summer Mode at air temperatures at or above 25°C.
- Power usage with Comfort Heater disabled.

### PRODUCT CODES

Code	Description
ATL	ATMOS
ATL-W	ATMOS - Wireless Remote Control Unit
ATL-A	ATMOS - App Control Unit

\*ATMOS Inline units are a designed specifically for properties with air restricted loft spaces to draw fresh air from outside throughout the year

# TECHNICAL DATA SHEET

## ATMOS® | Whole House Positive Input Ventilation Unit

### CONSTRUCTION

Durable ABS plastic body.

### MOTOR

Incorporates DC motor technology with sealed for life ball bearings designed to operate continuously at a pre-set 'background' rate.

### FAN

Ø146mm dual inlet forward curved centrifugal fan.

### FILTER

The unit has a synthetic fibre based filter made to ISO Coarse 65% in accordance with the ISO 16890 standard.

### SERVICING / MAINTENANCE

Filter change/inspection is required at 5 years. Various service options are available towards the end of the warranty period. The existing unit may remain in position to ensure minimal disruption. Any old components may be returned for recycling.

### WARRANTY

Covered by a 10 year warranty, subject to the completion of specified maintenance.

### ACCREDITATIONS

Conforms to the requirements of the UK Building Regulations and the Technical Standards for Ventilation.

Conforms to requirements of the EC directives relating to Electromagnetic Compatibility and Electrical Safety (EMC and LVD).  
CE Marked.

### SPARES & ANCILLARIES

Spares & Ancillaries	Code
Replacement coarse particle filter (ISO coarse 65%)	FILTERPIV-COARSE
Replacement medium particle filter (ePM10 50%)	FILTERANC-MEDI
Replacement fine particle filter (ePM2.5 50%)	FILTERANC-FINE
Replacement coarse particle filter including carbon (ISO coarse 65% including carbon)	FILTERANC-COARSE+C
EnviroVent diffuser	1DIF EVL SML1
Ø125 Kit for 3 floor installation, fire diffuser & ducting	KIT-PIV-SMOKE-125
Ø150 Kit for 3 floor installation, fire diffuser & ducting	KIT-PIV-SMOKE-150
Ø200 Kit for 3 floor installation, fire diffuser & ducting	KIT-PIV-SMOKE-200

Smoke alarm	1ACSMOKEALARM-KIT
AirSens® CO2*	AIR-CO2
AirSens® VOC*	AIR-VOC
AirSens® RH*	AIR-RH

\*W and A units only

### DIMENSIONS (MM)

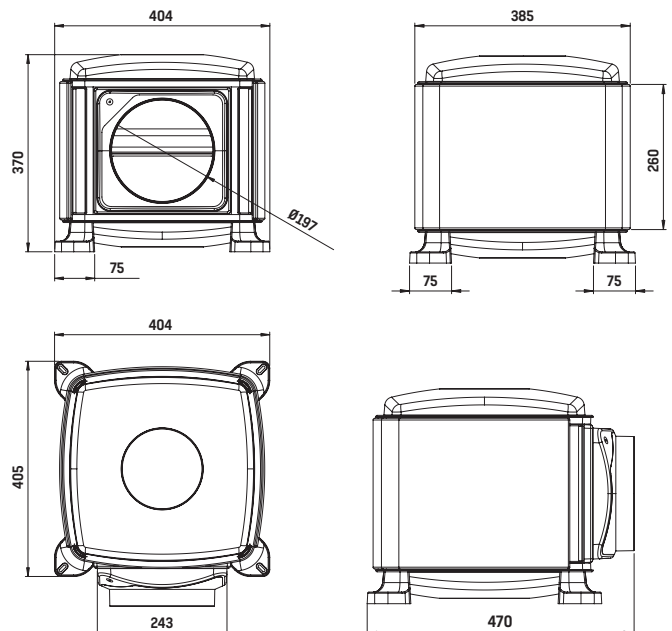

TECHNICAL DATA SHEET  
ATMOS® | Whole House Positive Input Ventilation Unit

PERFORMANCE CURVE

