

AFTER INSTALLATION THE END USER SHOULD
KEEP THIS GUIDE FOR FUTURE REFERENCE
DO NOT THROW AWAY

envirovent®

CYCLONE 8

INSTALLATION GUIDE FOR ENGINEER / INSTALLER



230V - IPX4

SELV - IPX5



Lifetime Range®

Safety

Read and understand these instructions before beginning installation. The unit should be installed by a competent person.

Check there is space to fit the unit in your chosen location. As standard it can be installed using 100mm or 125mm inside diameter duct. With the optional adaptor, a 150mm duct can also be used.

The unit can be wall mounted as standard, or ceiling, recess, inline and window mounted using optional kits (see page 15 for further information). The unit cannot be wall mounted upside down (with the electronic boards at the bottom) as this will void the warranty.

Ensure the operation of the unit does not affect the operation of open-flue appliances. If you are unsure, please consult local regulations or a qualified gas engineer. Consider the external cowl location in relation to open-flues from appliances e.g. boilers. You must ensure the cowl is positioned a minimum distance of 300mm away in all directions. EnviroVent recommends at least 2m clearance.

In kitchens, if the unit is fitted above a cooker, it must be installed a minimum distance of 1 metre above any hob, and not have a pullcord fitted.

This unit is not intended for use by persons (including children) with reduced physical, sensory or mental capabilities or lack of experience and knowledge, unless they have been given supervision and usage instruction by a person responsible for their safety.

Children should be supervised to ensure they do not play with the unit. Cleaning and user maintenance must not be performed by children.

Electrical Connection

The unit must be able to be disconnected from the Mains supply after installation. When wiring the unit to the Mains power supply, a suitable local isolator must be incorporated in the fixed wiring in accordance with the IET Wiring Regulations.

Connection to the fixed wiring must be made outside the unit in a suitable location, following IET Wiring Regulations.

The power cable running into the cable gland must remain the supplied flexible cable (not a solid core lighting and mains cable). If any other type of cable is forced into the cable gland, the unit will be damaged, voiding the warranty.

If the mains cable is damaged, it must be replaced by EnviroVent, an authorized service agent, or a similarly qualified person in order to avoid a hazard.

Do not remove or tamper with the electronic circuit boards inside the product. The unit requires a continuous electrical power supply and should not be wired through a light switch.

Wiring Regulations

All wiring must comply with Building Regulations and the current IET Wiring Regulations [BS7671 in the UK] or equivalent standards for other countries. The final installation should be examined and tested by a qualified electrician.

The fuse in the pattress box [SELV Variants] may need to be changed if the product is installed outside of the UK.

This product is not suitable for use with a Type AC RCD 

Diagrams

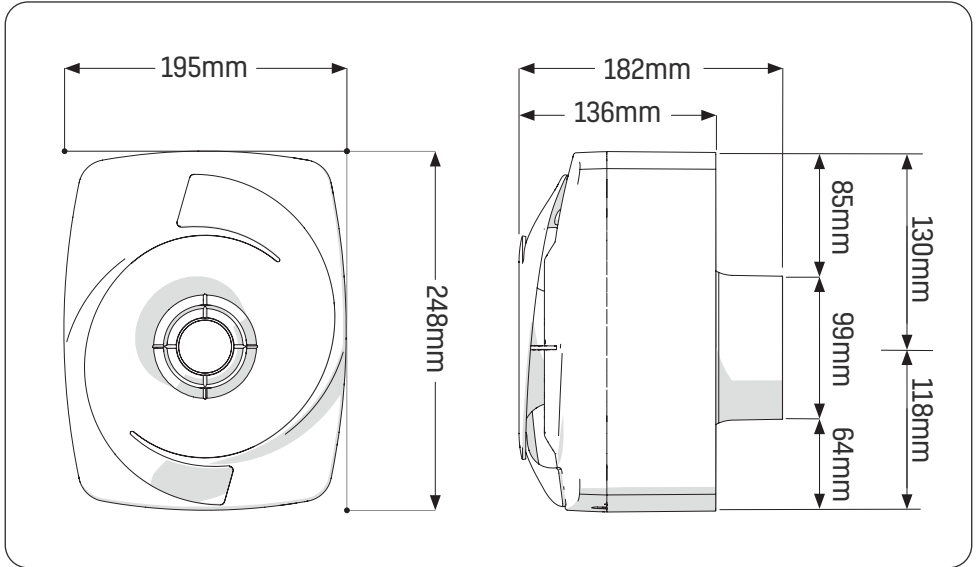
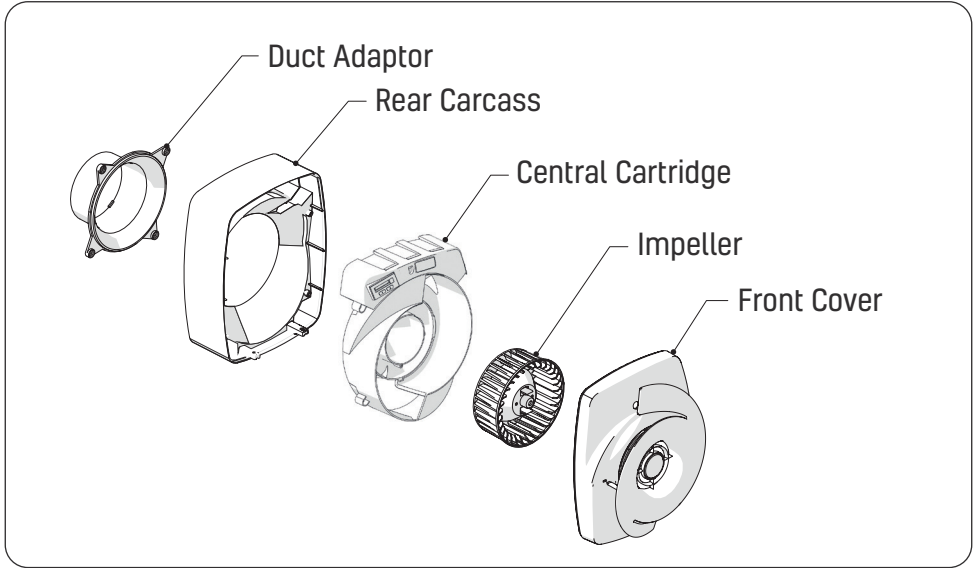

AFTER INSTALLATION THE END USER SHOULD
KEEP THIS GUIDE FOR FUTURE REFERENCE

**DO NOT
THROW AWAY**

Wiring Diagrams

230V

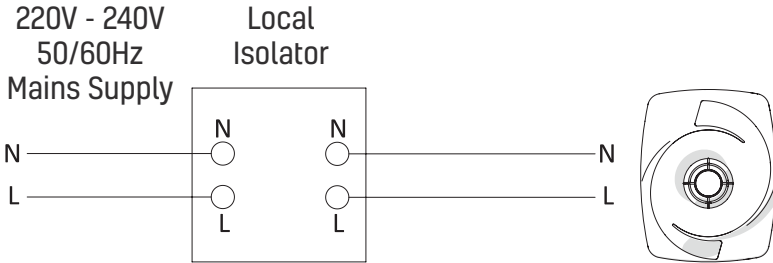

Connect the local isolator to the Mains as part of the fixed wiring. Connect the N and L connectors of the fan power cable to the local isolator.

SELV

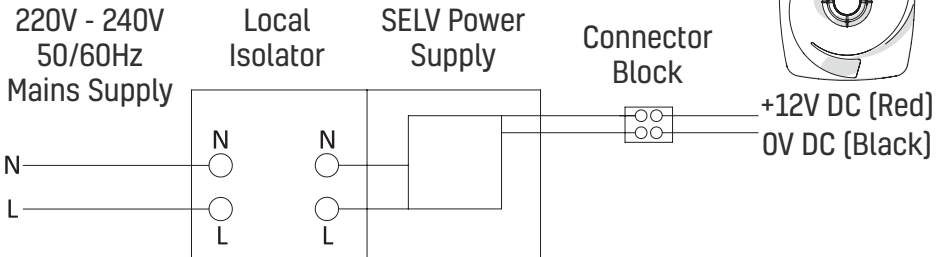

The red 12V cable from the unit must be connected to the red cable on the SELV power supply using the supplied terminal block. The black 12V cable from the unit must be connected to the black cable on the SELV power supply using the supplied terminal block.

About the Product

Function

The EnviroVent Cyclone 8 has been developed to improve indoor air quality, reduce humidity levels in kitchens and bathrooms and resolve condensation and mould problems. It is designed to operate continuously for up to 8 years without a major service.

Datalogger

The Cyclone 8 includes a datalogger as standard which is able to provide the following:

- The total running time of the fan
- The time the fan has spent in each of the two speeds (trickle and boost).
- The time the fan has spent in periods of increased humidity.
- The energy usage of the fan.

This data can be provided for 30 days and 12 months (with the exception of the total running time). If required, all data with the exception of the total run time is able to be reset. For further information on this, please call EnviroVent on 01423 810 810.

Variable Speed Control

As standard, the Cyclone 8 includes the option for variable speed control of the lower trickle speed for both larger properties and to ensure building regulation compliance. This can be accessed via the datalogging keypad under the front cover of the fan and has 25 increments from the factory set point up to 100% airflow.

Humidity Tracking

As standard, the unit is fitted with Intellitrac® Technology to sense the relative humidity in the room. Once above the setpoint, the fan speed will increase as humidity levels rise and decrease as humidity levels fall. This intelligent function reduces energy costs, motor wear, and ensures a long life for the product.

Pullcord

If your Cyclone 8 fan includes a pullcord, it can be used to engage the maximum extraction rate for odour control. Pull down on the cord to increase the unit to the maximum extraction rate. Pull down again to decrease the unit back to the low extraction rate.

Cartridge Replacement

If necessary, the central cartridge can be exchanged for a replacement. The removed cartridge can be returned to EnviroVent for recycling. This allows the front cover, rear carcass and duct to remain intact throughout the life of the property, eliminating the wasteful disposal of non-biodegradable material to landfill sites.

Installation

ISOLATE THE MAINS SUPPLY BEFORE BEGINNING THE INSTALLATION

1. Loosen the two screws on the bottom of the unit, leave the screws in place and remove the front cover.
2. Pull the central cartridge out from inside the rear carcass.
3. Disconnect the green connector end of the power cable from the unit then set the central cartridge to one side.
4. Connect the power cable and local isolator to the Mains as in the wiring diagrams **shown on page 5**. Then tighten the cable gland on the rear carcass.

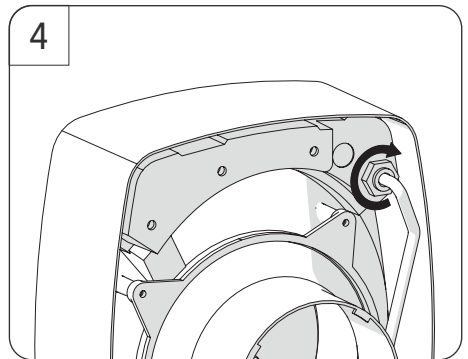
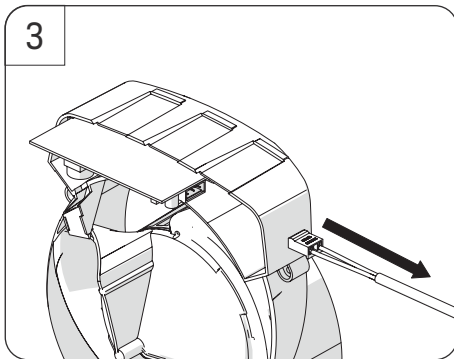
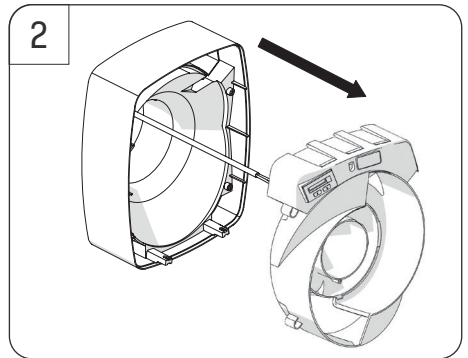
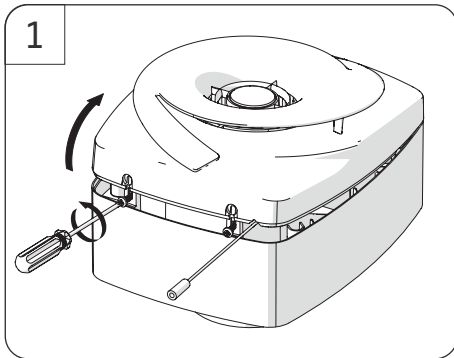

5. Insert the rear carcass into the wall duct.
6. Fix to the wall using four of the labelled fixing holes and the four screws and wall plugs provided.
7. If using a backdraught shutter, insert it fully. The disc must open towards the outside of the property.
(Do not fit this if the unit is ceiling mounted).
8. Insert provided caps into the fixing holes at the top of the rear carcass [1, 2, 3].
Not using these will void the IP rating and warranty.

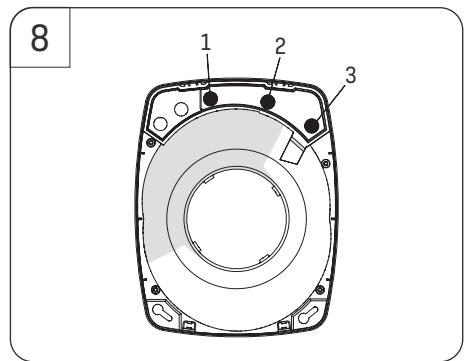
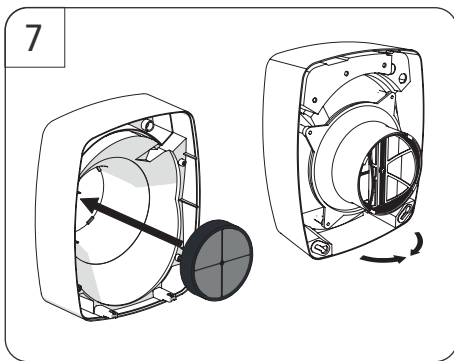
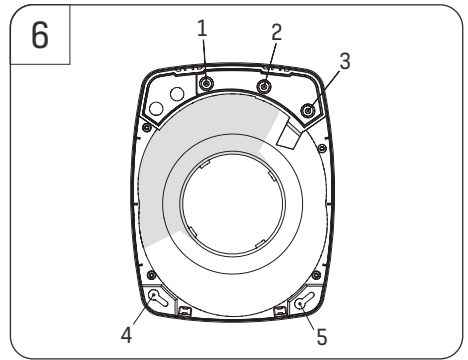
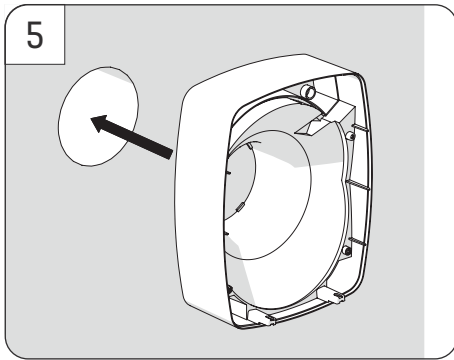

9. Reconnect the green power connector to the unit.
10. Insert the central cartridge into the rear carcass. Do not trap any of the cables. Fix in place using the four supplied screws.
11. To change unit settings, adjust switches 1 and 2 on the central cartridge.
 - a) Default 230V duty is kitchen and Standard Trickle.
 - b) Default SELV duty is bathroom and Standard Trickle.

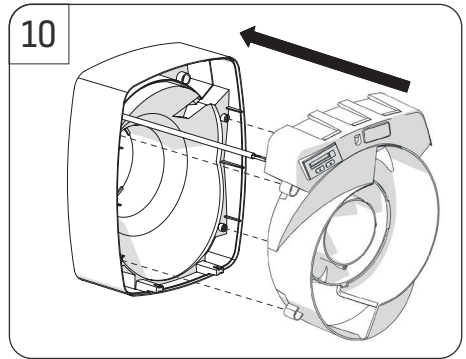
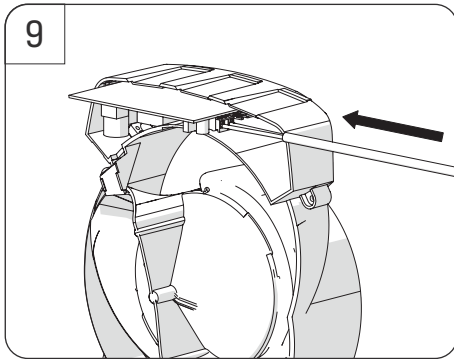

11a 230V

1		2		PCB RELEASE DO NOT TOUCH	
L	R	L	R		

Switch 1:
Left = Standard Trickle
Right = Trickle+

Switch 2:
Left = Kitchen Duty
Right = Bathroom Duty

11b SELV

1		2		PCB RELEASE DO NOT TOUCH	
L	R				

Switch 1:
Left = Standard Trickle
Right = Trickle+

Switch 2:
Not in use.
Bathroom Duty only

12. Now apply the adhesive foam pad over the switches.
Not using this will void the warranty and IP rating.
13. Ensure the impeller is fitted correctly, the two clips should both be engaged.
14. Replace the front cover ensuring the pullcord sits into the slot. Then tighten the two screws.
- The unit will not operate without the front cover in place.**
15. The mains supply can now be reactivated.

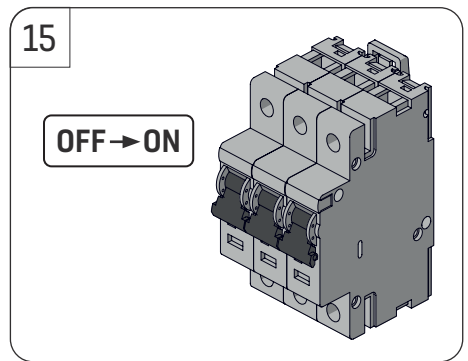
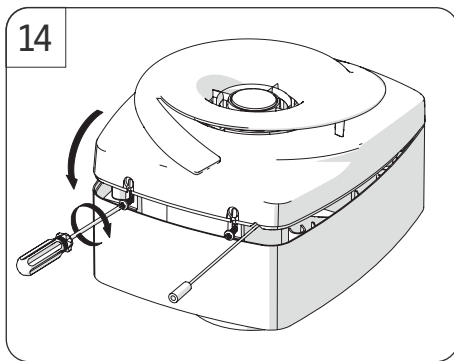
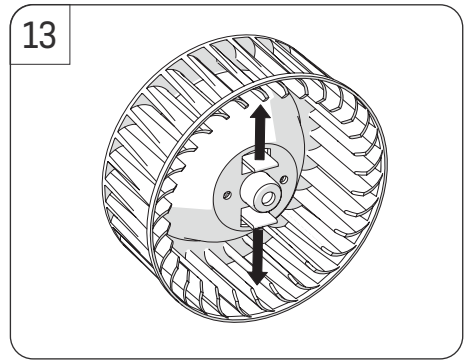
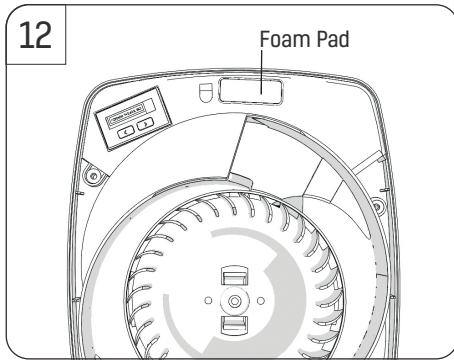

Datalogger and Variable Speed Control Operation

Data Logger

1. Loosen the screws and the front cover from the fan.

Note: the screw should not be fully removed

2. The display will automatically light up with the total run time.
3. Using the left hand arrow button below the display, cycle through to show options for:
 - The total running time of the fan
 - The time spent in trickle or boost
 - The time spent in periods of increased humidity
 - Energy usage in kWh.
4. Use the right hand arrow button below the display to show the collected data over either 30 days or 12 months [except the total run time].

5. All data apart from the total run time reset.

For further information on this setting, please call 01423 810 810.

6. Once the front cover is secured on the front of the fan the screen switches off. If the cover is then removed again, the datalogger defaults back to the last screen that was accessed.
7. If the buttons below the display are not pressed for 30 seconds the display will switch off. The screen will light up again once the buttons are pressed.
8. Once the necessary data is collected, replace the cover and screws for the fan to resume operation.

Datalogger and Variable Speed Control Operation

Variable Speed Control

1. Loosen screws and front cover from the fan.
2. The display will light up automatically to show the datalogger menu.
3. Press and hold the right arrow button for ten seconds until 'Kitchen Trickle' or 'Bathroom Trickle' appears. This is dependent upon the fan setting switch which can be adjusted using steps 11a and 11b on the installation menu.
4. The screen will also show 'Default' which means that the fan is currently programmed to run at the minimum trickle speed based upon the performance data on page 15. Using the right hand arrow increases the speed by 4% per press.
5. This continues up to 100%, with 25 increments.
5. Once the trickle speed has been increased, using the left hand arrow will decrease the trickle speed by 4% per press.
6. Once the appropriate trickle speed is selected, replace the front cover and screws and the fan will run as indicated.

Performance Checklist

- Is there power being supplied to the unit?
- Are all internal electrical connectors attached or have any been disconnected?
- Has the electronic circuit board been removed for any reason?
- Is the central cartridge correctly seated in the rear carcass with no stray wires obstructing it?
- Does the impeller spin freely? Ensure the two clips have been fully engaged.
- Is the front cover in place? The unit will not operate until the front cover is fitted.
- Does the pullcord activate? Ensure the pullcord is not trapped inside the unit.

ON-SITE INSTALLATION AFTER SALES SERVICE

Please ensure that you have read and understood the installation instructions. In the event of an on-site installation problem, or if you have any queries about the unit, just call us and ask to talk to a member of our technical team. In the majority of cases the issue can be resolved over the phone.

HOTLINE NUMBER: 01423 810 810

In cases where the problem cannot be resolved over the phone, contact your wholesaler to agree a return.

On-site call outs are available, note that charges may apply.

Cleaning

ISOLATE THE UNIT FROM THE MAINS SUPPLY BEFORE CLEANING

1. Remove the front cover.
2. Push the impeller clips towards the centre, then pull the impeller out. **Ensure that the small black hole underneath is clear of debris as this houses the Intellitrac sensor.**
3. Clean the front cover and impeller in warm soapy water and allow to dry. Use a damp cloth to clean any other parts of the unit. **(Do not use solvents and do not clean any parts in a dishwasher appliance).**
4. Clip the impeller back into position, ensuring the clips are engaged. Replace the front cover and tighten both screws.

THE UNIT WILL NOT OPERATE UNTIL THE FRONT COVER IS FITTED

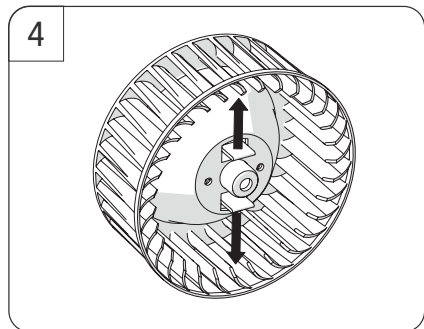
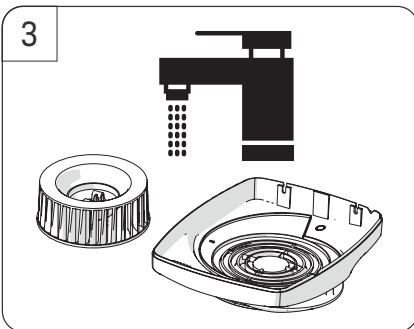
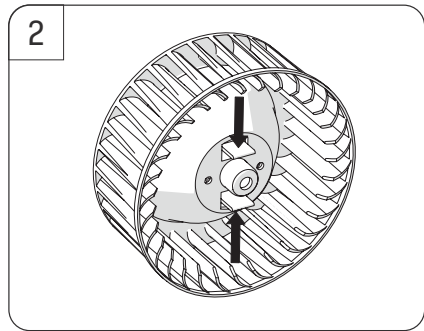
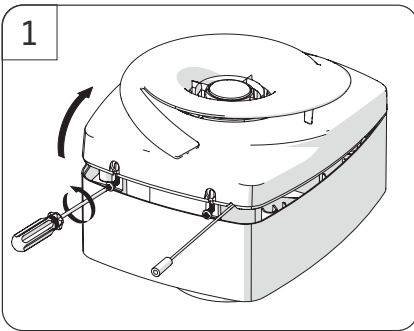

Airflow Performance*

Setting	Power (W)	Duty (L/s)
Bathroom Trickle	3	14
Bathroom Trickle+	4	21
Bathroom Boost	14	41
Kitchen Trickle	3	19
Kitchen Trickle+	4	22
Kitchen Boost	30	55

Running costs

Bathroom & Kitchen

Please scan our QR code to see the annual running costs of this product.



Or visit: envirovent.com/annual-running-costs

SELV variants run on bathroom duty only.

*The figures shown are factory set and will vary if the variable speed and datalogger function are being used.

Product Variants

Wireless Remote Control

When the button on the remote control is pressed, the unit will extract at the maximum extraction rate for up to 15 minutes then return to the low extraction rate. The high extraction rate can be stopped early if required, by pressing the button on the remote control within the 15 minutes. [Remote control units do not include a pullcord].

Wired Remote Switch

On these units, a wired boost switch may be connected up to 3 metres away from the unit. [This must be a volt free contact - do not wire the cable or switch into the Mains]. When the remote switch is activated, the unit will operate at the maximum extraction rate. It will remain at this rate until the switch is deactivated.

To pair additional remote-control switches:

1. Turn the unit off at the isolation point.
2. Restore power; for 20 seconds from restart the unit will be in pairing mode.

3. Press the remote button once within the 20 seconds and the control will pair to the unit.
4. Successful pairing is indicated by a green light on the control.

Batteries

When the battery [CR2032 type] requires changing, unscrew the switch front cover. The battery is located on the back of the cover. The switch will remain paired with the unit after battery replacement. Ensure the new battery is inserted with correct polarity, and the removed battery is safely disposed of.

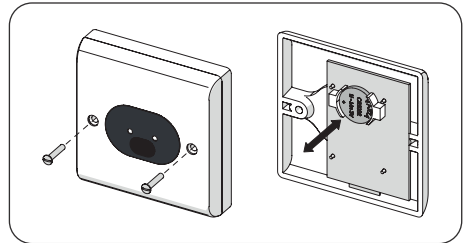

Optional Components

Description	Order codes	Description	Order codes
150mm Spigot Adaptor	1RDSPIG150	Window Mount Kit [230V]	CYC-WIK-230V
Remote Pullcord	EFHTCM-RC	Window Mount Kit [SELV]	CYC-WIK-12V
External Wall Grille Kit	1RDEFWAK	In-line Mount Kit	KITINLINEFAN
Ceiling/Recess Mount Kit	1ACEFCMBR		

Warranty

We appreciate you choosing this quality EnviroVent product, which is designed and manufactured to the highest specification in Harrogate, North Yorkshire. We are confident that you will be delighted with the performance of the system and the resulting improvement in air quality in your home after the installation of the unit.

The EnviroVent Cyclone 8 is covered by a full 8-year warranty which will benefit the occupier over many years. There is no requirement for maintenance within the first 8-year period other than general cleaning.

Your warranty covers any defect or break down that arises due to faulty materials or construction. Please note that a receipt will be required as proof of purchase. Units bought from an unapproved source, including but not limited to auction websites, are not covered by this warranty.

Your fan serial number

For warranty conditions and exclusions, visit
www.envirovent.com/warranty

What should I do if I have a problem?

You should not dismantle or remove any parts of the unit other than those instructed in this guide. Tampering with the unit will void the warranty. If you detect a fault, please contact us on **01423 810 810**.



Delivering innovative and sustainable ventilation solutions worldwide



Upon disposal, this unit and its parts should be recycled if possible. Contact your local authorities for recycling facilities and further advice.

EnviroVent Ltd
Harrogate West Business Park
Unit 1 Bardner Bank
Killinghall
Harrogate
HG3 2SP

T / 01423 810 810
E / info@envirovent.com
W / envirovent.com

**AFTER COMPLETING INSTALLATION, PASS THIS GUIDE
ONTO THE END USER FOR FUTURE REFERENCE
DO NOT THROW AWAY**

Boxed unit weight:	Unboxed unit weight:
230V: 1.65 kg	230V: 1.45 kg
SELV: 1.85 kg	SELV: 1.25 kg

E&OE | MKT ENV1019 - V2 - 02.05.24

Due to our policy of continuous innovation and improvement EnviroVent reserves the right to alter products specification and appearance without notice.

We want to hear from you

Your feedback is important to us as we strive to improve our products, services, and overall customer experience. Please email us to help us serve you better: feedback@envirovent.com