

TECHNICAL DATA SHEET EnergiSava 260 | Lightweight & Compact Whole House Heat Recovery System

A



KEY FEATURES

- ✓ Compact and lightweight with single person installation, weighs 14Kg with the depth measurement protruding from a wall no more than 305mm
- ✓ Easy commissioning via a push button commissioning pad or via the MyEnviroVent App if specified
- ✓ High efficiency counter flow cell capable of up to 88% thermal efficiency and extremely low Specific Fan Power (SFP) down to 0.57 W/l/s
- ✓ ErP Grade A
- ✓ 2 year warranty
- ✓ Integral Intellitrac® humidity tracking controls
- ✓ Wireless remote boost switch as standard which also indicates the mode of operation and filter indicator
- ✓ Automatic and integral thermal bypass to control entering the home on warmer days

PRODUCT

The energiSava® 260 shall be a compact and lightweight whole house heat recovery ventilation system.

APPLICATION SUITABILITY

The system shall be suitable for use in small to mid-sized houses with kitchen plus up to three wet rooms and designed primarily for new build and major renovations. The unit shall be capable of being either floor, wall or ceiling mounting. It shall be suitable for installation in an accessible loft or internal cupboard space. It shall be a single person installation with easy commissioning features. The unit shall incorporate Ø125 extract and supply spigots.

PRODUCT CHARACTERISTICS DATABASE (PCDB)

Exhaust Terminal Configuration	Specific Fan Power (W/l/s)	Heat Recovery Efficiency [%]
Kitchen + 1 wet room	0.57	88
Kitchen + 2 wet rooms	0.68	85
Kitchen + 3 wet rooms	0.83	83
Kitchen + 4 wet rooms	1.02	82
Kitchen + 5 wet rooms	1.29	81

TECHNICAL SPECIFICATIONS

Maximum Flow Rate	86l/s (310m³/hr)
Heat Exchanger	Counter Flow (Plastic)
Efficiency	88%
Fans	EC
Specific Fan Power	0.57 W/l/s
Electrical Supply	230V / 1PH / 50Hz
Max Power Consumption	145W
Protection Class	IPX2
Supply Filter	ISO Coarse 45% (G3)
Extract Filter	ISO Coarse 45% (G3)
Spigot (mm)	125
Dimensions (mm)	560 x 635 x 260
Weight	14Kg

SAP 2012

ⓑ

TECHNICAL DATA SHEET

EnergiSava 260 | Lightweight & Compact Whole House Heat Recovery System

INSTALLATION

Full installation guide shall be enclosed with all products; or sent separately in advance if required.

MOTOR

The unit shall incorporate Ultra Low Watt EC motor technology to provide the lowest possible SFP and unit running costs with sealed for life ball bearings and designed to operate continuously at a pre-set 'background' rate.

FAN IMPELLER

EC motors shall power the centrifugal forward curved fan impellers.

HEAT EXCHANGE CELL

The heat exchange cell shall be a high efficiency counter flow cell capable of up to 88% efficiency.

SERVICING / MAINTENANCE

Supply and extract filters shall be located within the unit and exchanged annually. The unit shall incorporate a heat exchange cell for life and shall not require any maintenance within five years.

FILTRATION

The unit shall be supplied with plug out / plug in ISO Coarse 45% (G3) filters on the supply and extract inlets.

WARRANTY

The unit shall be covered by a two year warranty subject to the specified maintenance and servicing.

CONTROLS

The unit shall be fitted with Intellitrac® humidity tracking system and a single switch live input with wireless boost. The wireless controller shall also indicate when the summer by-pass, frost and humidity tracking functions are activated.

MANUFACTURER

Unit shall be the EnergiSava® 260 as manufactured by EnviroVent Ltd.

ACCREDITATION

- SAP PCDB Listed
- Conforms to the requirements of the UK Building Regulations and the Technical Standards for Ventilation
- Conforms to requirements of the EC council directives relating to Electromagnetic Compatibility and Electrical Safety (LDV and EMC).
- CE Marked

SIZE

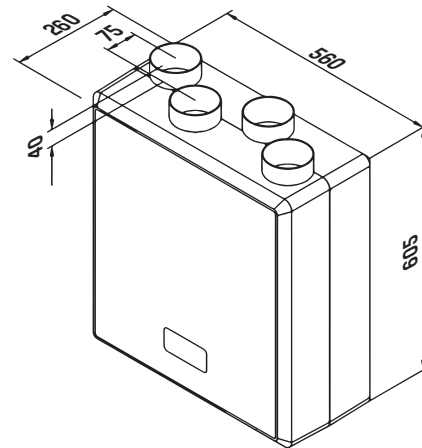

PERFORMANCE CURVE

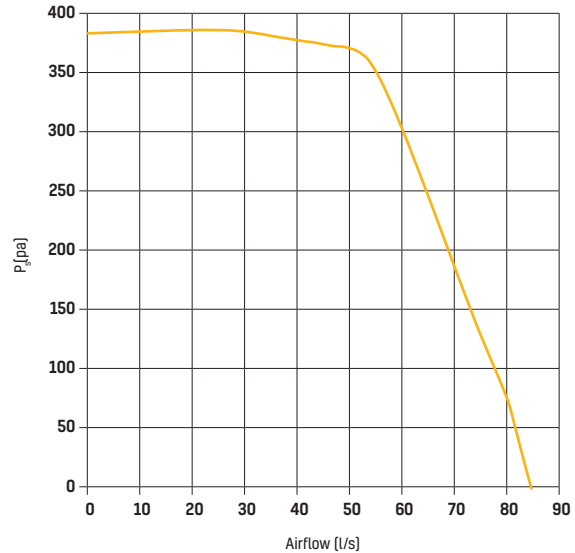

A full Consultant Specification can be sent on request.