

TECHNICAL DATA SHEET EnergiSava 300 | High Efficiency Whole House Heat Recovery System

* **A+** **A**



KEY FEATURES

- ✓ Low Specific Fan Power (SFP) of 0.62 W/l/s and high thermal efficiency of 89%
- ✓ Constant flow technology to deliver the required airflow at all times
- ✓ 100% automatic integral mechanical bypass with no reduction in airflow
- ✓ 4-way hard-wired switch to indicate the mode of operation and filter change indicator
- ✓ Pre-heater to warm the incoming air when the temperature falls below 5°C
- ✓ 'Plus' version available for additional 0-10V or volt-free connection options, such as a CO₂ sensor
- ✓ Left or right-hand configurations
- ✓ Passive Haus Certified

PRODUCT

The energiSava® 300 shall be a high efficient, constant flow whole house heat recovery system.

APPLICATION SUITABILITY

The energiSava® 300 is ideal for residential properties to provide a constant supply of clean, tempered air and maintain stable humidity levels. With maximum airflow capacity of 300 m³/h, the unit shall be available in left-handed and right-handed versions with a range of options for connecting the ducts. A 'Plus' version shall also be available featuring additional connection options such as a CO₂ sensor.

PERFORMANCE

Ventilation capacity at 150Pa (m ³ /h)	Rated power at 70% of the max appliance capacity (W)
Max 300	40 at 210 m ³ /h & 50 Pa

PRODUCT CHARACTERISTICS DATABASE (PCDB)

Exhaust Terminal Configuration	Specific Fan Power (W/l/s)	Heat Recovery Efficiency (%)
Kitchen + 1 wet room	0.66	89
Kitchen + 2 wet rooms	0.62	87
Kitchen + 3 wet rooms	0.66	86
Kitchen + 4 wet rooms	0.74	85
Kitchen + 5 wet rooms	0.86	84
Kitchen + 6 wet rooms	1.04	83
Kitchen + 7 wet rooms	1.21	83

*Note: 'A+' rating only applicable with 2 or more sensors

SAP 2012

SOUND POWER

Ventilation capacity (m ³ /h)		90		150		210		300	
Sound power level L _w (A)	Static pressure (Pa)	50	100	50	100	50	100	50	100
	Housing emission dB(A)	30	33	38	38	44	46	50	52
	Duct "from dwelling" dB(A)	33	34	39	42	45	46	54	54
	Duct "to dwelling" dB(A)	44	47	52	55	60	60	67	67

In practice, the value may deviate 1 dB(A) as a result of measuring tolerances

TECHNICAL DATA SHEET

EnergiSava 300 | High Efficiency Whole House Heat Recovery System

CONTROLS

The unit shall be controlled with the choice of either a 4-way switch with filter indication (1 supplied as standard) or a wireless remote control. Alternatively, using the intelligent control module with timer, or the relative humidity sensor, and/or the 2-zone demand flow system enables automatic ventilation control and saves even more energy.

MOTOR

The unit shall incorporate Ultra Low Watt EC motor technology to provide the lowest possible SFP and unit running costs with sealed for life ball bearings and designed to operate continuously at a pre-set 'background' rate.

FAN

EC motors shall power the centrifugal backward curved fan impellers.

HEAT EXCHANGE CELL

The heat exchange cell shall be a high efficiency counter flow cell.

SUMMER BYPASS & FROST PROTECTION

The energiSava® 300 unit shall incorporate a 100% mechanical summer bypass and preheater as standard. The bypass contributes to an improved comfort level in summer and is controlled automatically by measuring indoor and outdoor temperatures. The intelligent frost protection with preheater guarantees the high efficiency, even at extremely low temperatures. This energy-efficient frost protection helps to achieve significant energy savings per year.

CONSTANT FLOW CONTROL

The 'constant flow' technology ensures maximum efficiency and that the commissioned airflow rate is always delivered despite any resistance encountered in the ductwork or filters. The 'constant flow control' system also enables commissioning to be carried out much quicker and more easily, saving on installation costs.

FILTRATION

The unit shall incorporate 2 x ISO Coarse 45% (G3) filters with the option of an ePM1 50% (F7) supply filter.

SERVICING / MAINTENANCE

Supply and extract filters shall be located within the heat cell unit and exchanged annually. The unit shall incorporate a heat exchange cell for life and shall not require any maintenance within five years.

WARRANTY

The unit shall be covered by a 2 year warranty on parts and 5 years on the heat exchanger subject to the specified maintenance and servicing.

INSTALLATION

Full installation guide shall be enclosed with all products; or sent separately in advance if required. The unit shall be capable of being wall mounted with the wall mounted suspension kit. The unit shall be suitable for installation in a utility room or cupboard space. The unit shall incorporate the intelligent digital display panel for ease of commissioning. The energiSava® 300 shall incorporate Ø150/160mm extract and supply spigots.

SIZE

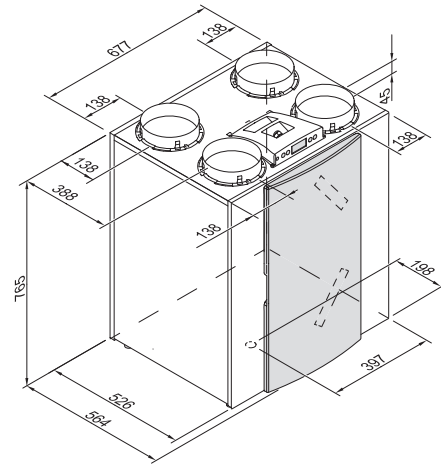

PERFORMANCE CURVE

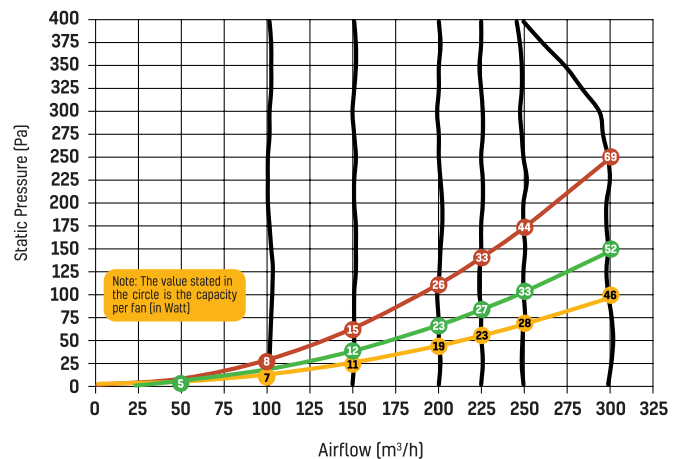

TECHNICAL SPECIFICATIONS

Ventilation capacity at 150 Pa (m³/h)	Max 300
Rated power at 70% of the max appliance capacity (W)	40 at 210 m³/h & 50 Pa
Dimensions / Duct Connection (mm)	Ø150/160
Weight	38Kg
Temperature efficiency	89%
Constant flow control	✓
Standard bypass	✓
Standard preheater	✓
Connections provisions for humidity sensor	✓
Connections provisions for 2-zone demand flow	✓
Connection for timer	✓
Available as Plus version*	✓

A full Consultant Specification can be sent on request.

ENV1140 V1 22/10/24