

TECHNICAL DATA SHEET EnergiSava 400 | High Efficiency Whole House Heat Recovery System

* **A+** **A**



KEY FEATURES

- ✓ Extremely low Specific Fan Power (SFP) of 0.61 W/l/s and high thermal efficiency of 89%
- ✓ 100% automatic integral mechanical bypass with no reduction in airflow
- ✓ Integral humidity sensor
- ✓ Stepped reduction intelligent frost protection
- ✓ Hard-wired LED status indicator
- ✓ Summer kick-up mode for increased airflow
- ✓ Left or right-hand configurations
- ✓ 3 year warranty

PRODUCT

The energiSava® 400 shall be a high efficient, constant flow whole house heat recovery system.

APPLICATION SUITABILITY

The energiSava® 400 is ideal for residential properties to provide a constant supply of clean, tempered air and maintain stable humidity levels. With maximum airflow capacity of 400 m³/h, the unit shall be available in left-handed and right-handed versions with a range of options for connecting the ducts. A 'Plus' version shall also be available featuring additional connection options such as a CO₂ sensor.

PERFORMANCE

Ventilation capacity at 150Pa (m ³ /h)	Rated power at 70% of the max appliance capacity (W)
Max 400	64 at 280 m ³ /h & 50 Pa

PRODUCT CHARACTERISTICS DATABASE (PCDB)

Exhaust Terminal Configuration	Specific Fan Power (W/l/s)	Heat Recovery Efficiency (%)
Kitchen + 1 wet room	0.63	89
Kitchen + 2 wet rooms	0.61	89
Kitchen + 3 wet rooms	0.66	87
Kitchen + 4 wet rooms	0.74	86
Kitchen + 5 wet rooms	0.84	85
Kitchen + 6 wet rooms	0.95	84

*Note: 'A+' rating only applicable with 2 or more sensors

SAP 2012

SOUND POWER

In practice, the value may deviate 1 dB(A) as a result of measuring tolerances

Ventilation capacity (m ³ /h)		100		200		225		300		400		
Sound power level Lw (A)	Static pressure (Pa)	9	40	38	80	47	100	84	175	240	150	225
	Housing emission dB(A)	29.5	32.5	40.5	40.5	43.5	47.5	51.0	53.0	54.0	54.5	57.0
	Duct "from dwelling" dB(A)	31.5	34.5	46.5	48.0	48.5	50.0	56.5	57.0	58.0	59.0	60.0
	Duct "to dwelling" dB(A)	42.5	47.5	57.0	59.0	60.5	62.5	66.0	68.5	69.5	70.5	71.5

TECHNICAL DATA SHEET

EnergiSava 400 | High Efficiency Whole House Heat Recovery System

CONTROLS

The unit shall be controlled with the choice of either a 4-way switch with filter indication (1 supplied as standard) or a wireless remote control. Alternatively, using the intelligent control module with timer, or the relative humidity sensor, and/or the 2-zone demand flow system enables automatic ventilation control and saves even more energy.

MOTOR

The unit shall incorporate Ultra Low Watt EC motor technology to provide the lowest possible SFP and unit running costs with sealed for life ball bearings and designed to operate continuously at a pre-set 'background' rate.

FAN

EC motors shall power the centrifugal backward curved fan impellers.

HEAT EXCHANGE CELL

The heat exchange cell shall be a high efficiency counter flow cell.

SUMMER BYPASS & FROST PROTECTION

The energiSava® 400 unit shall incorporate a 100% mechanical summer bypass and preheater as standard. The bypass contributes to an improved comfort level in summer and is controlled automatically by measuring indoor and outdoor temperatures. The intelligent frost protection with preheater guarantees the high efficiency, even at extremely low temperatures. This energy-efficient frost protection helps to achieve significant energy savings per year.

CONSTANT FLOW CONTROL

The 'constant flow' technology ensures maximum efficiency and that the commissioned airflow rate is always delivered despite any resistance encountered in the ductwork or filters. The 'constant flow control' system also enables commissioning to be carried out much quicker and more easily, saving on installation costs.

FILTRATION

The unit shall incorporate 2 x ISO Coarse 45% (G3) filters with the option of an ePMI 50% (F7) supply filter.

SERVICING / MAINTENANCE

Supply and extract filters shall be located within the heat cell unit and exchanged annually. The unit shall incorporate a heat exchange cell for life and shall not require any maintenance within five years.

WARRANTY

The unit shall be covered by a 2 year warranty on parts and 5 years on the heat exchanger subject to the specified maintenance and servicing.

INSTALLATION

Full installation guide shall be enclosed with all products; or sent separately in advance if required. The unit shall be capable of being wall mounted with the wall mounted suspension kit. The unit shall be suitable for installation in a utility room or cupboard space. The unit shall incorporate the intelligent digital display panel for ease of commissioning. The energiSava® 400 shall incorporate Ø180mm extract and supply spigots.

SIZE

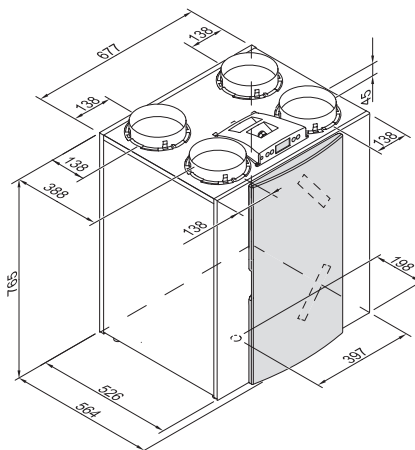

PERFORMANCE CURVE

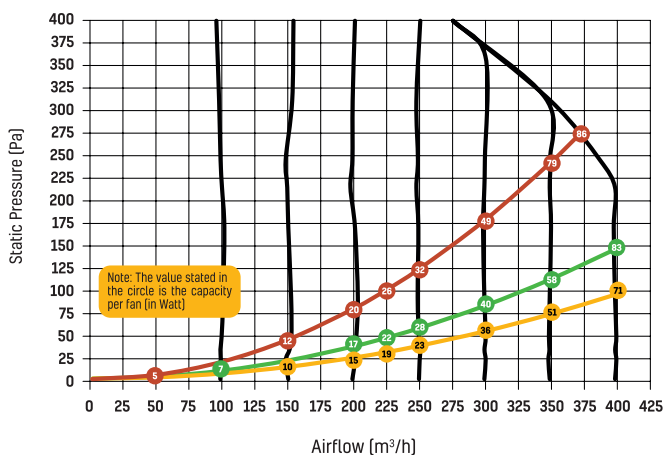

TECHNICAL SPECIFICATIONS

Ventilation capacity at 150 Pa (m³/h)	Max 400
Rated power at 70% of the max appliance capacity (W)	64 at 280 m³/h & 50 Pa
Dimensions / Duct Connection (mm)	Ø180
Weight	38Kg
Temperature efficiency	89%
Constant flow control	✓
Standard bypass	✓
Standard preheater	✓
Connections provisions for humidity sensor	✓
Connections provisions for 2-zone demand flow	✓
Connection for timer	✓
Available as Plus version*	✓

A full Consultant Specification can be sent on request.