

## TECHNICAL DATA SHEET

### Silent 125 & 150 | Ultra Quiet Kitchen & Utility Fans



#### KEY FEATURES

- ✓ Sealed for life ball bearings
- ✓ Silent elastic blocks
- ✓ IP45 rated
- ✓ Backdraught shutter and airflow guide vanes as standard
- ✓ 5 or 7 year warranty
- ✓ Quiet running
- ✓ High performance
- ✓ Pullcord option
- ✓ Significant energy savings
- ✓ Complies with local building regulations

#### PRODUCT

The SILENT 125 & 150 are innovative domestic axial extract fans designed to offer a low level of noise. The SILENT 125 is designed to solve ventilation problems in small rooms and the SILENT 150 is designed for kitchens. The fans are fitted with a pilot light, backdraught shutter and airflow guide vanes as standard.

#### APPLICATION SUITABILITY

The SILENT 125 & 150 can be wall or ceiling mounted to meet the Building Regulations - Part F (England), Scottish Building Standards and Part K (Northern Ireland). The fans will ventilate domestic small rooms and kitchens.

#### INSTALLATION

Full installation guide is enclosed with all products; or sent separately in advance - if required.

#### MOTOR

The motor is a 230V 50Hz A/C motor, which is assembled on silent elastic blocks and fitted with ball bearings for enhanced working life. The patented silent technology ensures minimum noise possible.

#### FAN

The impeller is axial flow type.

#### SERVICING / MAINTENANCE

The extract fan only requires periodical cleaning using a damp cloth and soap. Ensure fan is completely dry before turning back on.

#### WARRANTY

5 year warranty applies to: SIL150P & SIL150HTP. 7 year warranty applies to: SIL125S, SIL125T, SIL125HT, SIL150S, SIL150T & SIL150HT.

#### CONTROLS

The SILENT 125 & 150 are available in various models which include integral controls. The options available include an adjustable timer, adjustable humidity sensor and pullcord. Further details on set points for the timer and humidity sensor can be found in the installation guide.

#### TECHNICAL SPECIFICATIONS

MODEL	SILENT 125	SILENT 150
Maximum Flow Rate	50l/s (180m <sup>3</sup> /h)	72 l/s (260 m <sup>3</sup> /h)
Motor	AC	AC
Electrical Supply	230V / 50Hz	230V / 50Hz
Max Absorbed Power	16W	29W
Protection Class	IP45	IP45
Spigot (mm)	118	146.5
Dimensions (mm)	180 X 180 X 119 (including spigot)	214 X 214 X 148.8 (including spigot)
Weight	0.77kg	1.25kg

**TECHNICAL DATA SHEET**  
**Silent 125 & 150 | Ultra Quiet Kitchen & Utility Fans**

**DIMENSIONS (MM)**

SILENT 125

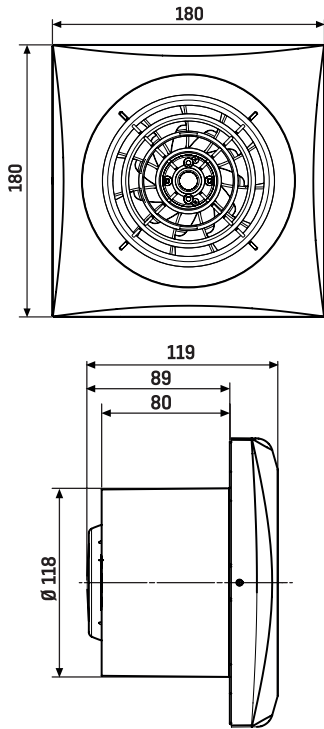

SILENT 150

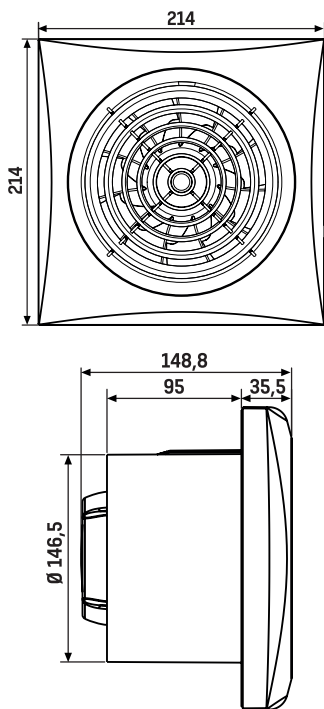

**PERFORMANCE CURVE**

SILENT 125

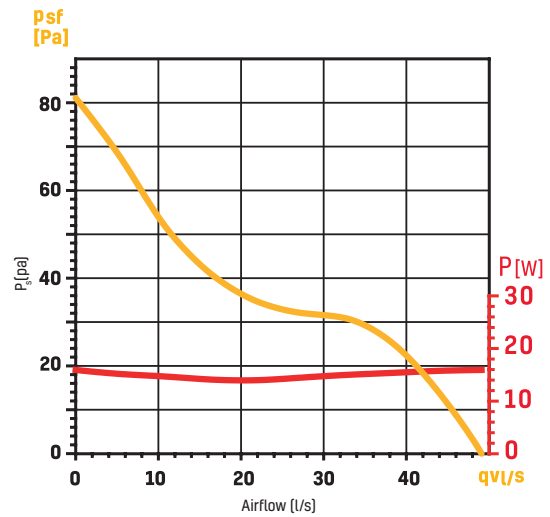

SILENT 150

