

TECHNICAL DATA SHEET Slimline 150 | High Efficiency, Low Profile Heat Recovery System

A



KEY FEATURES

- ✓ Low Specific Fan Power (SFP) of 0.75 W/l/s and high thermal efficiency of up to 88%
- ✓ 100% automatic integral mechanical bypass with no reduction in airflow
- ✓ Integral humidity sensor
- ✓ Intelligent frost protection
- ✓ Intelligent control module as standard
- ✓ Left or right-hand configurations
- ✓ 2 year warranty

PRODUCT

The Slimline 150 shall be a constant flow, low profile whole house heat recovery ventilation system.

APPLICATION SUITABILITY

The high-efficiency and constant flow EnviroVent Slimline 150 is ideal for ceiling mounted or wall mounted applications such as apartments, care homes, offices and student accommodation to provide optimum ventilation. The Slimline 150 achieves a maximum airflow rate of 150 m³/h with thermal efficiency of up to 88%. A 'Plus' version shall also be available featuring additional connection options such as a CO₂ sensor.

PERFORMANCE

Ventilation capacity at 150Pa (m ³ /h)	System sound emission dB(A)	Rated power at 70% of the max appliance capacity (W)
Max 150	<40 at 75 m ³ /h & 100 Pa	36 at 105 m ³ /h & 50 Pa

PRODUCT CHARACTERISTICS DATABASE (PCDB)

Exhaust Terminal Configuration	Specific Fan Power (W/l/s)	Heat Recovery Efficiency (%)
Kitchen + 1 wet room	0.75	88
Kitchen + 2 wet rooms	0.73	88
Kitchen + 3 wet rooms	0.81	85

SAP 2012

ACCREDITATIONS

- Conforms to the requirements of the UK Building Regulations and the Technical Standards for Ventilation
- Conforms to requirements of the EC council directives relating to Electromagnetic Compatibility and Electrical Safety (LDV and EMC).
- CE Marked
- SAP PCDB Listed
- Passive House Certified

SOUND POWER

In practice, the value may deviate 1 dB(A) as a result of measuring tolerances

Ventilation capacity (m ³ /h)		45			75			105		150	
Sound power level Lw [A]	Static pressure (Pa)	10	50	100	25	50	100	50	100	50	100
	Housing emission dB(A)	24	33	39	33	35	40	38	41	44	45
	Duct "from dwelling" dB(A)	27	36	42	34	37	42	40	43	46	47
	Duct "to dwelling" dB(A)	41	49	58	50	53	57	57	60	62	64

TECHNICAL DATA SHEET

Slimline 150 | High Efficiency, Low Profile Heat Recovery System

CONTROLS

The unit shall come as standard with the intelligent control module, that can be used to adjust the settings and airflow rates. The built-in timer function can be used to set the ventilation rate per day/week/weekend. Additionally, one or more 4-way switches, wireless RF controls or a humidity sensor may be installed.

MOTOR

The unit shall incorporate Ultra Low Watt EC motor technology to provide the lowest possible SFP and unit running costs with sealed for life ball bearings and designed to operate continuously at a pre-set 'background' rate.

FAN

EC motors shall power the centrifugal forward curved fan impellers.

HEAT EXCHANGE CELL

The heat exchange cell shall be a high efficiency counter flow cell.

SUMMER BYPASS & FROST PROTECTION

The Slimline 150 unit shall incorporate a 100% mechanical summer bypass and preheater as standard. The bypass contributes to an improved comfort level in summer and is controlled automatically by measuring indoor and outdoor temperatures. The intelligent frost protection with preheater guarantees the high efficiency, even at extremely low temperatures. This energy-efficient frost protection helps to achieve significant energy savings per year.

CONSTANT FLOW CONTROL

The 'constant flow' technology ensures maximum efficiency and that the commissioned airflow rate is always delivered despite any resistance encountered in the ductwork or filters. The 'constant flow control' system also enables commissioning to be carried out much quicker and more easily, saving on installation costs.

FILTRATION

The unit shall incorporate 2 x ISO Course 60% [G4] filters with the option of an ePM1 50% [F7] supply filter.

SERVICING / MAINTENANCE

Supply and extract filters shall be located within the unit and exchanged annually. The unit shall incorporate a heat exchange cell for life and shall not require any maintenance within five years.

WARRANTY

The unit shall be covered by a 2 year warranty on parts and 5 years on the heat exchanger subject to the specified maintenance and servicing.

INSTALLATION

Full installation guide shall be enclosed with all products; or sent separately in advance if required. The unit shall be capable of being wall or ceiling mounted with the brackets supplied. The unit shall be suitable for installation in an accessible ceiling void or wall mounted with easy commissioning features. The Slimline 150 shall incorporate Ø125 mm extract and supply spigots.

SIZE

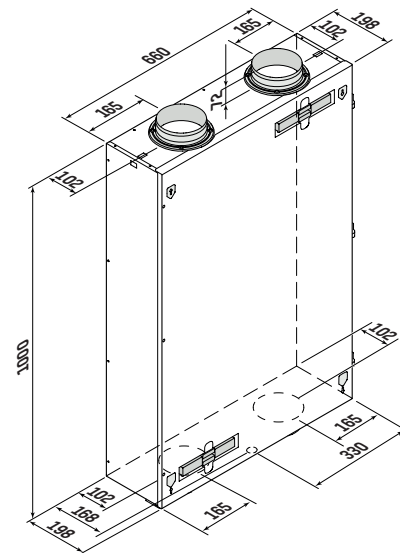

PERFORMANCE CURVE

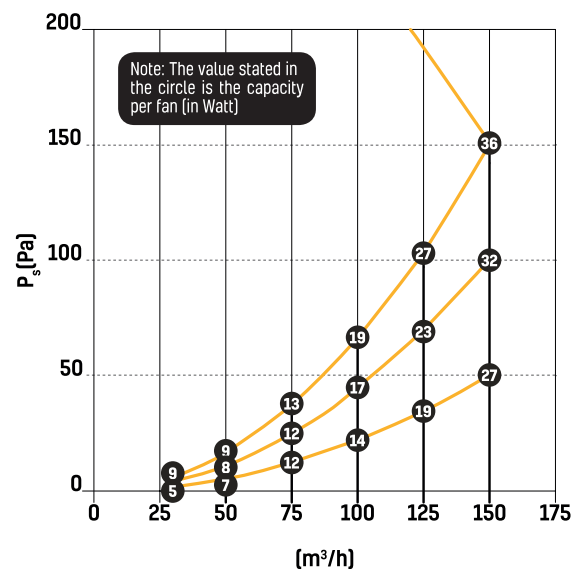

A full Consultant Specification can be sent on request.